

Pandora would like to thank you for choosing our DXL 1940L service and security system

Pandora DXL 1940L is a premium car service-security system, built for cars with on-board voltage of 12V. It is a complex engineering solution which includes car security system, telemetry, remote and automatic engine start and various service options, all controlled from your OEM key remote, smart-phone or online service.

When building **Pandora DXL 1940L** we were using the most up-to-date electronics from world's best manufacturers. The device is built using high-precision mounting and control machinery, thus we guarantee highest possible quality, reliability and stable technical characteristics for the whole operation period.

Pandora DXL 1940L has a cryptographically strong authorization code with unique dialog algorithm and individual 128 bit encryption key on every device. We guarantee 100% protection from electronic hacking for the whole operation period.

The system is built for your convenience: it's ergonomic, reliable, has the highest security and service characteristics, 3 years unconditional warranty and free service and support on the territory of Russian Federation and nearest states. We are happy to provide any support we can – feel free to use our online support.



WARNING! IT IS STRONGLY ADVISED TO HAVE PROFESSIONAL CAR MECHANIC INSTALLING THE SYSTEM. ANY CAR ELECTRONICS INSTALLER SHOULD BE ABLE TO INSTALL PANDORA DXL 1940L USING INSTALLATION SCHEME IN THIS MANUAL AND ALARMSTUDIO SOFTWARE. MOST FEATURES ARE HIGHLY DEPENDENT ON COMPETENT INSTALLATION. OUR SYSTEMS ARE THOROUGHLY TESTED FOR QUALITY, SO IF A FEATURE FAILS TO PRODUCE EXPECTED RESULTS, MOST LIKELY THE PROBLEM IS IN IMPROPER INSTALLATION

This device has limited external factors resistance. It should not be subjected to water beyond occasional splatter, or operated in temperatures outside -40 to +80° C range. All system components must be installed only in a car interior..

IMPORTANT! Note that this manual describes remote and manual functions for the most part. Functionality of the system is vast and would require a book-sized manual to fully describe. Instead we use handy software named AlarmStudio that functions as both programming tool and an extended installation & functionality manual. It requires Windows and can be downloaded at pandorainfo.com

Our web site: www.pandorainfo.com
Customer support: support@pandorainfo.com



Product is in conformity with Electromagnetic Compatibility Directive EMC 2004/108/EC and R&TTE Directive 1999/5/EC

Table of contents

System features	4
Car security zones	5
System set	5
Control over the system	6
Arming/disarming using radio tag	6
Arming/disarming in Hands Free mode	6
Arming/disarming in «Slave» mode	6
Immobilizer mode	7
Anti-Hi-Jack-1 mode	7
Anti-Hi-Jack-2 mode	8
Code immobilizer using original car controls	8
Maintenance mode	8
Replacing immobilizer tag battery	9
Control over the system in case of emergency	10
Emergency disarming using VALET button	10
Enabling/disabling immobilizer radio tag	12
Control over the system via a phone	13
DTMF – commands	13
Changing settings via phone	16
Online service and mobile application	18
Installation and configuration of the system	23
Installation requirements	23
Wiring diagram	24
RMD-5M connection diagram	26
Wiring description	27
Programming the systems	29
Preparing to program the system using a computer	30
Updating firmware	31
Additional devices	39

Information

Siren sounds and turn light signals	41
Service sound signals of the «Beeper»	41
Meaning of indicator LED colors	42
Checking the number of recorded radio tags/mobile device	43
System modules layout	43
Warranty obligations	44
Installation certificate	45
Acceptance certificate	46
Warranty card	46

SYSTEM FEATURE

Base unit

- Android and iOS applications.
- Individual PIN-code to disarm and switch off immobilizer.
- Hands Free mode for arming/disarming.
- 2 Antihijack modes.
- Automatic arming
- Validator mode
- Algorithms of original immobilizer bypass.
- Integrated GPS/GLONASS receiver
- Integrated GSM-interface.
- Built-in 2,4 GHz module with support of Bluetooth 4.2 Low Energy protocol.
- Dialog coding of control commands.
- Individual 128-bit encryption key.
- Built-in integral accelerometer for determining motion and shocks with adaptive processing algorithm and sensitivity controls.
- Advanced process of sensor data reading, eliminating false alarm possibilities
- Built-in temperature sensor.
- Firmware updates via built-in micro-USB socket.
- Support for additional devices: digital blocking relay BM-105, blocking radio relay BTR-101, radio hood module RHM-03BT, wireless door sensor DMS-100BT.

Bluetooth tag

- Dialog coding of control commands.
- Individual 128-bit encryption key.
- Built-in LED indicator.
- Built-in button to control over security modes.
- Built-in integral accelerometer.

Car security zones

Pandora DXL 1940L service-security system guards following independent zones:

- car doors perimeter
- front hood triggers
- trunk triggers
- ignition trigger
- brake pedal pressing
- triggering of the built-in shock sensor (warning level)
- triggering of the built-in shock sensor (alarm level)
- triggering of the built-in motion sensor
- triggering of the built-in tilt sensor
- critically low on-board voltage
- parking lights left on notification when arming*.

System set

Base unit	1
Bluetooth tag	2
Cable with VALET button and three-colored light indicator	1
User installation manual	1
Plastic card with individual secret code	1
Engine temperature sensor	1
Relay module (optional)	1
Beeper	1
Main cable of the base unit	1
Analog blocking relay	1
IMMO-KEY interface cable	1
Fastening kit	1
Packaging	1

Manufacturer reserves the right to change set and construction of the product to improve its technological and operational parameters without notification.

* - Availability of this function depends on car make and model

CONTROL OVER THE SYSTEM

Arming/disarming using radio tag

To arm/disarm the system, RF tag should be in the Bluetooth coverage area. The system produces a protected (AES-128 encryption) interactive high-speed exchange of authorization codes in the frequency range 2,4 GHz on one of 125 channels. To arm the system when the ignition is switched off, shortly press the tag button. The system will confirm the command receiving with 1 short sound signal and 1 flash of turn indicators. To disarm the system, shortly press the tag button. The system will confirm the command receiving with 2 short sound signals and 2 flashes of turn indicators. Each button press will be confirmed with LED indicator flash of the tag that indicates the battery is functioning correctly. If LED indicator does not flash or light, the tag battery should be replaced (see 'Replacing immobilizer tag battery' section).



Arming/disarming in Hands Free mode

The system allows for programmable Hands Free arming and disarming. To arm the system, when the engine is not running, move with the remote tag away from the car at a distance greater than the regular radio coverage (10 meters for 2,4 GHz) – the system will be armed automatically. To disarm the system, move toward the car with remote tag. Enabling/disabling this function can be performed with a phone (see 'Control over system via a phone' section).

Arming/disarming in «Slave» mode

In this mode, it is possible to monitor the status of original security system of the car via CAN-bus or by analog inputs. When arming and disarming original security system, Pandora will be armed and disarmed respectively. The presence of a tag in the radio zone is not required, but at the beginning of motion if the tag is not detected by the system, the engine will be blocked.

There is an option named 'Disable disarming when the tag is not present' in the system settings. When this option is enabled, disarming procedure will be performed only if there is a tag in the radio zone.

Immobilizer mode

This mode is enabled by default. Use a phone to disable this mode (see 'Control over system via a phone' section). When switching on the ignition, the base unit of Pandora security system performs a search for immobilizer tags in radio zone. If no radio tags were detected when the ignition is switched on, the system will block the engine with all radio relays that were programmed into the system. Engine blocking will only occur when motion sensor detects movement of the car. If additional analogue blocking relays were installed, they will block the engine immediately, before or when the car starts moving, it depends on system settings.



WARNING! IF THE SYSTEM DOESN'T RECOGNIZE A RADIO TAG, THE BEEPER WILL EMIT 5 SOUND SIGNALS WHEN THE IGNITION IS TURNED ON, THIS WILL REPEAT 5 TIMES. CHECK THE RADIO TAG BATTERY, MOVE THE TAG (IT GOES TO A SLEEP MODE WHEN IT REMAINS MOTIONLESS AND THE IGNITION IS SWITCHED OF. A BUILT-IN ACCELEROMETER HAVE TO RECOGNIZE MOVEMENT TO ACTIVATE THE TAG).

Anti-Hi-Jack-1 mode

This mode is disabled by default. Use Pandora Alarm Studio application to enable this mode. Anti-hi-jack mode helps to prevent aggressive seizure of the car using delayed engine blocking on door opening.

Every time on opening/closing a door when the ignition is switched on, immobilizer requests response from a radio tag using unique algorithm. After a door was opened while the engine is running, if the system cannot detect a radio tag, the engine will be stopped after 1 minute (general safety requirement). A siren will play 'ENGINE BLOCKING WARNING' ringtone before blocking. The engine will be blocked immediately or when the car starts moving, it depends on system settings.



WARNING!
ANTIHIJACK MODE IS NOT LEGAL IN SOME COUNTRIES.

Anti-Hi-Jack-2 mode

This mode is disabled by default. Use Pandora Alarm Studio application to enable this mode. Anti-Hi-Jack-2 mode helps to prevent aggressive seizure of the car using delayed engine blocking on radio tag disappearance. The system requests a response from a tag using a unique algorithm when the ignition is switched on. If the system cannot detect a radio tag, the engine will be stopped after 1 minute (general safety requirement for car movement). «Engine blocking warning» ringtone will play from siren and beeper before blocking. When warning signals end, the system will block the engine. Engine blocking will occur immediately or when the car starts moving, it depends on block implementation and system settings.

Code immobilizer using original car controls

Code immobilizer (validator) is a function that allows disarming, disabling blocking and controlling timer channels using original car controls (button, lever or pedal). To enter immobilizer code, programmed button (lever, pedal) should be pressed a number of times equals the first digit of the code. Pauses between presses should not exceed 1 second. Pauses more than 1 second will be interpreted as the start of next digit input. Immobilizer code can consist max of 4 digits from 1 to 9. After entering a correct immobilizer code, depending on the settings, either the engine blocking will be lifted or a programmed timer channel will be activated or the system will be disarmed.

Maintenance (Valet) mode

It is recommended to put system into maintenance mode before handing it to the car service or valet parking. When this mode is switched on, security system stops interfering with built-in electronics and disables all functions to ease maintenance or parking. Moreover, you will not have to leave the remote control or radio tag to the valet or the mechanic. You can enable/disable this mode using a radio tag, mobile phone or immobilizer button (if the 'Code immobilizer' function is implemented).

Enable/Disable the maintenance mode using a radio tag:

To enable/disable the maintenance mode, the radio tag should be in the coverage zone. Enter the 'Immobilizer PIN-code' (if the 'Code immobilizer' function is implemented). Press and hold the button on the tag for 3 seconds to enable the maintenance mode.

Press and hold the button on the tag for 3 seconds again to disable the maintenance mode.

Enable/Disable the maintenance mode using a phone:

To enable the maintenance mode, disarm the system, switch on the ignition, the radio tag should be in the coverage zone (if the immobilizer/AntiHijack function is activated), enter the 'Immobilizer PIN-code' (if the 'Code immobilizer' function is implemented). Call the system number. Wait for answer.

- To enable maintenance mode, dial "Enable maintenance mode" DTMF command **551***
- Enter the 'Secret PIN-code' that is located on the owner's plastic card – the maintenance mode will be activated.
- To disable maintenance mode, dial **552*** DTMF command.

Enable/Disable the maintenance mode using an immobilizer button:

To enable the maintenance mode, disarm the system, switch on the ignition, the radio tag should be in the coverage zone (if the immobilizer/AntiHijack function is activated), enter the 'Immobilizer PIN-code' (if the 'Code immobilizer' function is implemented) and press the same button 10 times within 20 seconds after entering the PIN-code. To disable maintenance mode switch on the ignition and enter the 'Immobilizer PIN-code'.

Replacing immobilizer tag battery:

Carefully open the cover of the tag's battery compartment. Extract discharged battery and insert a new one keeping in mind the correct polarity. Replacing a battery will not cause a loss of tag code information, as authorization data is stored in the non-volatile memory of the MCU.

Carefully close the cover of the tag's battery compartment. All elements of construction should be rigidly locked in places. If it is so, the tag can be operated as usually.



Control over the system in case of emergency

Use a phone to deactivate the system quickly. To disarm the system via a phone, call the system's number. When it answers, dial command **0***. If the call is not made from the owner's number, guest PIN-code should be entered. Factory set guest PIN-code is **1-2-3-4**.

To switch off an immobilizer tag, dial the **998*** command (after dialing, enter the 'Secret PIN-code' that is located on the owner's plastic card). To switch on an immobilizer tag, dial the **888*** command. If the system cannot be deactivated via a phone, apply emergency disarming and switching on/off an immobilizer tag using VALET button.

Emergency disarming using «VALET» button



WARNING! MAKE SURE THAT A PROTECTIVE LAYER ON THE OWNER'S PLASTIC CARD IS INTACT AFTER THE INSTALLATION OF THE SYSTEM. THE PLASTIC CARD HOLDS THE 'SECRET PIN-CODE'.



WARNING! CAREFULLY REMOVE THE PROTECTIVE LAYER, DO NOT USE SHARP OBJECTS TO AVOID DAMAGING OF HIDDEN INFORMATION UNDER A PROTECTIVE LAYER.

In case you cannot disarm the system using a phone or immobilizer tag, the 'Secret PIN-code' can be used. The 'Secret PIN-code' is written on the owner's plastic card under protective layer. Erase the protective layer and use **VALET** button to input the PIN-code.

The code must be entered only when the base unit is powered and the ignition is switched off. The PIN-code can be entered using external or located on the base unit **VALET** button. The digits input and correct input is indicated by the external or located on the base unit **LED** indicator.

Entering the PIN-code

• Enter the first digit of the code using **VALET** button. Press the button a number of times, equals to the first digit. Pauses between presses should not exceed 1 second. Each pressing will be confirmed with an orange **LED** indicator flash. A Pause for more than 1 second and a red **LED** indicator flash confirm the input of the first digit. Then you can enter the next digit.

• Enter the second digit of the code using **VALET** button. Press the button a number of times, equals to the second digit. Pauses between presses should not exceed 1 second. Each pressing will be confirmed with an orange **LED** indicator flash. A Pause for more than 1 second and a red **LED** indicator flash confirm the input of the second digit. Then you can enter the next digit.

• Enter the third digit of the code using **VALET** button. Press the button a number of times, equals to the third digit. Pauses between presses should not exceed 1 second. Each pressing will be confirmed with an orange **LED** indicator flash. A Pause for more than 1 second and a red **LED** indicator flash confirm the input of the third digit. Then you can enter the next digit.

• Enter the fourth digit of the code using **VALET** button. Press the button a number of times, equals to the fourth digit. Pauses between presses should not exceed 1 second. Each pressing will be confirmed with an orange **LED** indicator flash.

The system will confirm correct PIN-code with the series of red and green flashes and the system will be disarmed. If the input was incorrect, it will be indicated with a red **LED** indicator flash and the system will stay in a previous state. New input can be attempted after 5 seconds.

If the system was disarmed and the ignition was switched off it will enter programming mode after correct input of the PIN-code.

For emergency arming when the ignition is switched off, press and hold **VALET** button for 3 seconds. The system will be armed in 30 seconds. Status LED indicator is lighting red during the countdown.

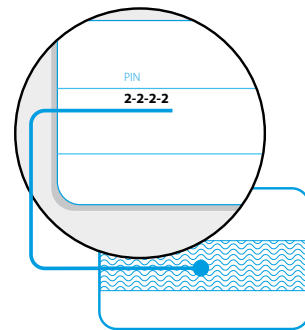

VALET BUTTON

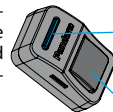

Three-color status LED indicator (green, red, orange)

VALET button

Enabling/Disabling immobilizer radio tag



WARNING!
IT IS HIGHLY RECOMMENDED TO CHANGE FACTORY PRESET OF THE "SERVICE PIN-CODE" FOR IMPROVING SECURITY OF THE SYSTEM.



Write down or remember the 'Service PIN-code'

To disable immobilizer radio tag, enter level 15 (the system should be in programming mode). Enter the 'Secret PIN-code' to disable radio tag or press **VALET** button once to enable radio tag.

Enter the "Service PIN-code" to enter programming mode (factory preset of the service PIN-code is '1-1-1-1'). You can enter the code only if the base unit is powered, the ignition is switched off, the system is disarmed and the maintenance mode is switched off. If there is no 'Service PIN-code', you can enter programming mode using the 'Secret PIN-code' written on the owner's card. After entering programming mode, press **VALET** button 15 times. Green color of **LED** indicator means a radio tag is switched on, red color means a radio tag is switched off.

Disabling radio tag:

LED indicator will light green after entering the programming level. The system will wait for entering the 'Secret PIN-code'. Enter the 'Secret PIN-code' that is written on the owner's plastic card. The system will confirm disabling of the radio tag with two sound signals of the siren and a long red LED flash. After that the system will return to the programming menu. If the PIN-code is not entered within 10 seconds or the input is incorrect, a siren will sound one signal, **LED** will produce the series of red and green flashes and the system will return to the programming menu.

Enabling radio tag:

LED indicator will light red after entering the programming level. The system will wait for action. Press **VALET** button once to enable radio tag. The system will confirm enabling with one short sound signal of a siren and a green **LED** light. After that the system will return to the programming menu.

CONTROL OVER THE SYSTEM VIA A PHONE

Call the system's phone number. When it answers, enter a command code.



WARNING!
IF THE CALL IS NOT MADE FROM THE OWNER'S NUMBER, GUEST PIN-CODE SHOULD BE ENTERED. FACTORY SET GUEST PIN CODE IS 1-2-3-4. AFTER THE SYSTEM IS INSTALLED, PLEASE CHANGE FACTORY SET PIN-CODE. 1-2-3-4.

#	Return to previous menu state	6 6 6 *	Enable engine blocking
*	Repeat the last message	9 9 9 *	Disable engine blocking
1 *	Arming	2 5 8 *	System information
0 *	Disarming	9 9 8 *	Disable immobilizer tag
1 0 *	Silent arming	8 8 8 *	Enable immobilizer tag
0 0 *	Silent disarming	2 2 2 *	Disable Hands Free mode
9 *	Help	2 2 3 *	Enable Hands Free arming
0 9 *	Event history	2 2 4 *	Enable Hands Free disarming
1 5 *	Tow truck mode	2 2 5 *	Enable Hands Free disarming only with autom. start
1 0 0 *	Request GSM account balance	7 8 9 *	Enable automatic engine start
1 2 3 *	Start the engine/prolong heating	9 8 7 *	Disable automatic engine start
3 2 1 *	Stop the engine	2 9 7 *	Call ended
3 3 3 *	Switch on add. function using F via CAN	5 5 1 *	Enable maintenance mode (see description below)
5 0 0 *	Request current coordinates	5 5 2 *	Disable maintenance mode
4 5 6 *	Switch on additional channel	1 5 6 *	Switch on engine preheater
6 5 4 *	Switch off additional channel	6 5 1 *	Switch off engine preheater

DTMF – commands.

For example: To have simple access to engine start function, create a new contact in the contact list of your phone, name it 'Engine start', for instance, and add the number in the following format: **+XXXXXXXXXXXX,123*,297*** where '+XXXXXXXXXXXX' – the system phone number, ',' - pause is a feature of the phone (can be displayed as the 'P'; see the instructions of the phone), '123*' - remote engine start DTMF command,

'297*' - end call DTMF command.

Contact can be added as a speed dial to any of the free button.

To have simple access to engine start function a phone other than the main owner's phone, create contact in the following format: +XXXXXXXXXXXX,1234,123*,297* where '1234' – guest PIN-code.

Enable/Disable maintenance mode

1. Call the system number. Wait for answer.
2. To enable maintenance mode, dial 'Enable maintenance mode' DTMF command 551* (the ignition should be switched on, radio tag should be in range if immobilizer/AntiHijack mode is active)
3. Enter the 'Secret PIN-code' that is located on the owner's plastic card.
4. To disable maintenance mode, dial 552* DRMF command.

Voice help

The system has voice help menu. During voice call to the system, dial 9* and listen to the information about system control commands. To end session, hang up the phone.

Repeat the last message

To repeat any message, press * during a voice call to the system

Arming/disarming

Pandora system has function of promptly disabling automatic engine start.

1. Call the system number. Wait for answer.
2. Dial 1* to arm, and 0* to disarm
3. For silent arming dial 10* or 00* for silent disarming
4. The system will confirm arming/disarming.



WARNING!
ENABLE REMOTE START ONLY IF YOUR LOCAL LEGISLATION ALLOWS DRIVER-LESS CARS TO HAVE WORKING ENGINE.

Enabling/disabling automatic engine start

1. Call the system number. Wait for answer.
 2. 987* to disable all automatic engine starts or 789* to enable all automatic engine starts
 3. The system will confirm the command execution
- To end session, hang up the phone
- Automatics starts can be enabled again by dialing 789* (all previous settings will remain intact)

Blocking/unblocking the engine

You can block car's engine using any phone. The engine will remain blocked until phone command 'Disable engine blocking' will be sent. This blocking cannot be disabled using a tag.

1. Call the system number. Wait for answer.
2. Dial 666* to enable engine blocking or 999* to disable engine blocking (after dialing 999*, you will need to enter the 'Secret PIN-code' that is located on the owner's plastic card).



WARNING! DISABLING OF THE ENGINE BLOCKING THAT WAS ENABLED VIA A PHONE 666* IS ALLOWED ONLY BY DIALING 999* AND ENTERING THE 'SECRET PIN-CODE'

Request current coordinates

1. Call the system number. Wait for answer.
 2. Dial 500*.
 3. The system will confirm: 'Current coordinate sent via text message' and will send text message with coordinates and a web link to a map to your phone.
- To end session, hang up the phone.
- An additional GPS/GLONASS receiver NAV-035 BT is required to determine the coordinates (see p. 39)

Request GSM account balance

1. Call the system number. Wait for answer.
 2. Dial 100*.
 3. The system will confirm: 'Balance information sent via text message' and will send text message with account balance information to your phone.
- To end session, hang up the phone.

Tow truck mode

This mode is intended for car transportation with preservation of arming function. Tow truck mode can be activated only when the system is armed, it will be deactivated automatically when disarming.

All other system commands can be entered in the same manner.

Changing core settings via phone

To enter settings programming mode:

1. Disarm the system
2. Call the system number. Wait for answer.
3. Switch ignition on for 1-3 seconds, then switch it off.

The system will enter settings programming mode.



WARNING!
THERE ARE ONLY TWO WAYS TO CHANGE THE OWNER'S PHONE NUMBER:
1. VIA A PHONE, USING CORE SETTINGS MENU.
2. VIA A COMPUTER AND PANDORA ALARMSTUDIO SOFTWARE

Example of changing the owner's system number:

1. Enter the setting menu via a phone according to the instruction above;
 2. Dial DTMF command **1***(phone number settings) and **1***(owner's system number);
 3. Enter new owner's number in the format *XXXXXXXXXX # (the system recognizes '*' as '+');
- To confirm, dial **1***

1 * Phone number settings	1 *	Owner's number -> #
	2 *	Additional owner's number -> #
	3 *	Second additional owner's number -> #
	4 *	Account balance inquiry number -> #
	5 *	System's number -> «#»
2 * Settings of the voice calls	1 *	Voice calls on alarm
	2 *	Voice calls on triggering warning level of the sensors
	3 *	Voice calls on engine start
	4 *	Voice calls on engine stop
	5 *	Voice calls on restoring GSM connection
	6 *	Voice calls on disarming
	7 *	Voice calls on entering programming mode
	8 *	Voice calls when radio relay connection is lost
	9 *	Voice calls when on-board voltage is low
0 *	Voice calls on accident	
3 * Settings of the text messages	1 *	Text messages on alarm
	2 *	Text messages on triggering warning level of the sensors
	3 *	Text messages on engine start
	4 *	Text messages on engine stop
	5 *	Text messages on restoring GSM connection
	6 *	Text messages on disarming
	7 *	Text messages on entering programming mode
	8 *	Text messages when radio relay connection is lost
	9 *	Text messages when on-board voltage is low
	0 *	Text messages on accident
	4 * Immobilizer settings	1 *
2 *		Antihack

5 * Additional settings	1 *	Changing guest PIN-code
	2 *	Entering as guest
	3 *	Remote blocking
	5 *	Set threshold voltage for sending text message
	6 * Automatic engine start settings	1 *
2 *		Set up time for automatic start
3 *		By voltage
4 *		Set up voltage for automatic start
5 *		By temperature
6 *		Set up temperature for automatic start
7 *		By period
8 *		Set up period for automatic start
7 * Sensor sensitivity settings	1 *	Settings of the warning level of the shock sensor sensitivity
	2 *	Settings of the alarm level of the shock sensor sensitivity
	3 *	Settings of the motion sensor sensitivity
	4 *	Settings of the tilt sensor sensitivity
	5 *	Settings of the warning level of the supplementary sensor sensitivity
	6 *	Settings of the alarm level of the supplementary sensor sensitivity
8 * Settings of saving mode	1 *	GSM connection
	2 *	Money saving mode of the GSM connection
	3 *	Voice calls in roaming service
9 * Current time and date settings	1 *	Set up date
	2 *	Set up time

NOTE: Engine start via temperature is available only if temperature sensor is connected. The sensor availability depends on the system set.

ONLINE SERVICE AND MOBILE APPLICATION

Warning! For the correct operation of the GSM functions, the owner should monitor the status/balance of the SIM card installed in the system. If the SIM card is blocked or defective, GSM functions of the system will be unavailable.

Registration

Visit pandora-on.com website and register following the instructions.

System login

After completing of the registration process, you can login to online service via a computer's web browser or via special mobile apps for the Android (Pandora Online) and iOS (Pandora Pro). Use your previously created login/password to enter the web-site or mobile app.

Adding a car to the online service

Internet service **pandora-on.com** can support simultaneously several telemetry systems, installed on various cars (private car park).

To add a telemetry system (car) to the service, press 'Add car' button and go through the process of adding, following the instructions.

To add a car, individual owner's card with registration information is needed (shipped with the system).

Event history

Event history holds more than 100 different types of events that can happen to the system. Every event is saved with date, time, coordinates (additional GPS/GLONASS receiver NAV-035 BT is required) and status of all control zones at the moment the event has occurred. The number of events in the history is limited. Storage of event history life is no less than 1 month.

Mobile apps for Android and iOS

You can download mobile apps from your device's app store (Google Play, App Store). To access the app, use the login data received from the service at the registration stage.



Control via radio channel

Mobile applications Pandora Online and Pandora Pro can control the system, receive status information and open advanced settings without Internet connection when the phone is in the Bluetooth coverage zone.

To get access to these functions, record the mobile device in the system memory (see "pairing/unpairing mobile device" section)

Paired device can operate as a radio tag to implement immobilizer, HandsFree, AntiHiJack functions. These functions can be adjusted (only in programming mode).



WARNING! CONTROL VIA BLUETOOTH CHANNEL IS AVAILABLE ONLY ON THE DEVICES WITH ANDROID 4.4 AND HIGHER AND IOS 9.3.5 AND HIGHER THAT SUPPORTS BLUETOOTH 4.0 LOW ENERGY AND HIGHER.

Event history	
18 of January	
09:00	Arming 165 Fleet St, London EC4A 2DY, UK 09:00
08:35	Disarming 218 st Johns street, London EC1V 4AT, UK 08:35
08:24	Engine start 218 st Johns street, London EC1V 4AT, UK 08:24
17 of January	
18:34	Arming 218 st Johns street, London EC1V 4AT, UK 18:34 <small>pandora-on</small>
18:00	Disarming 165 Fleet St, London EC4A 2DY, UK 18:00 <small>auto</small>
17:50	Engine start 165 Fleet St, London EC4A 2DY, UK 17:50 <small>time</small>
09:00	Arming 165 Fleet St, London EC4A 2DY, UK 09:00

08:24 Engine start
18 of January by command via online service

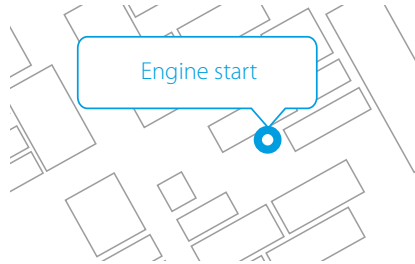
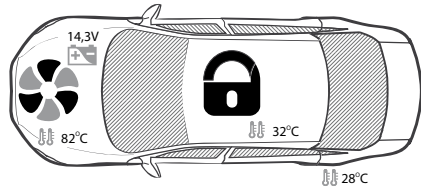

System status information

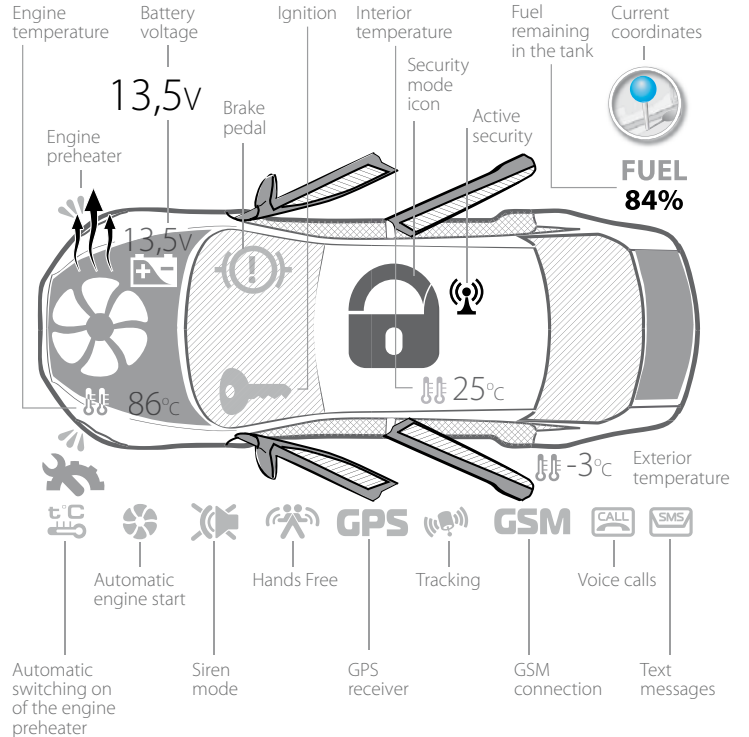

Security and warning zones

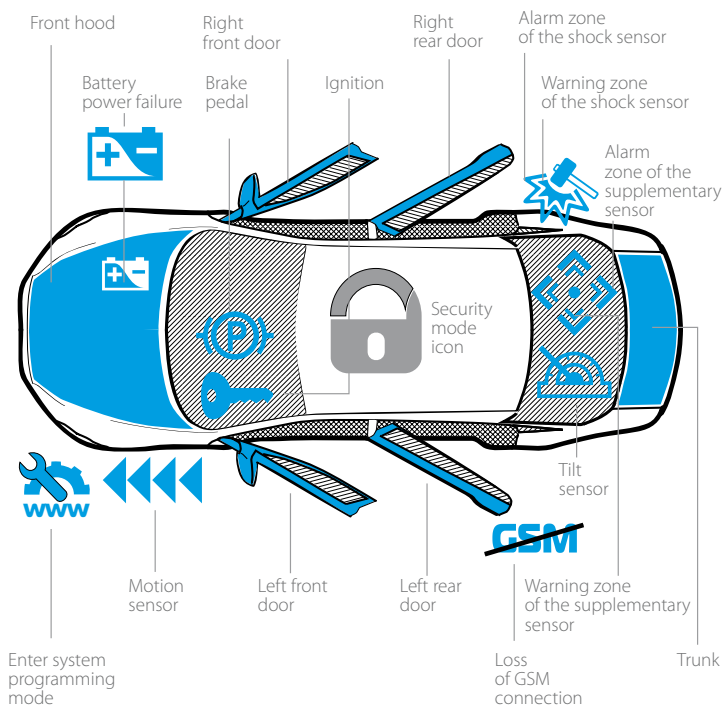

INSTALLATION AND CONFIGURATION OF THE SYSTEM

General installation requirements

Only install base unit inside car interior.

- Install securely each system's component, as conditions of the car standard operation can harm functionality of the alarm system and cause damage to the car original systems, including the elements of safety in motion.
- The system installation should be performed when the system sockets and the negative battery terminal are disconnected.
- The base unit power supply should be switched off when connecting to CAN-bus.
- The system installation can be performed via twisting together or via lead-tin soldering followed by isolation of a switching place.
- When wiring, pay attention to sections and materials of switched conductors, if they are different, bring electrochemical potentials to the minimal difference. The isolation should not allow for moisture to reach wiring, as the presence of moisture will increase electrochemical destruction of wires (this is especially important for the large current circuits).
- Switched connections should be placed as high as it is possible in the cavities so water condensate will not form drops on the switching location.
- To avoid the destruction of compounds by car vibration, ensure that there is a bit of free length to the wiring, providing enough sagging.
- Do not allow wiring in places where the wires isolation can be destroyed by abrasion.
- Electronic system units should be placed sockets down and as high as possible to avoid condensate reaching electronic components through the socket.
- When installing base unit, secure it to the car body for correct operation of in-built shock sensor.
- All unused system wires during the installation must be insulated and secured to prevent accidental touching of a car body or other wires

For remote engine start implementation

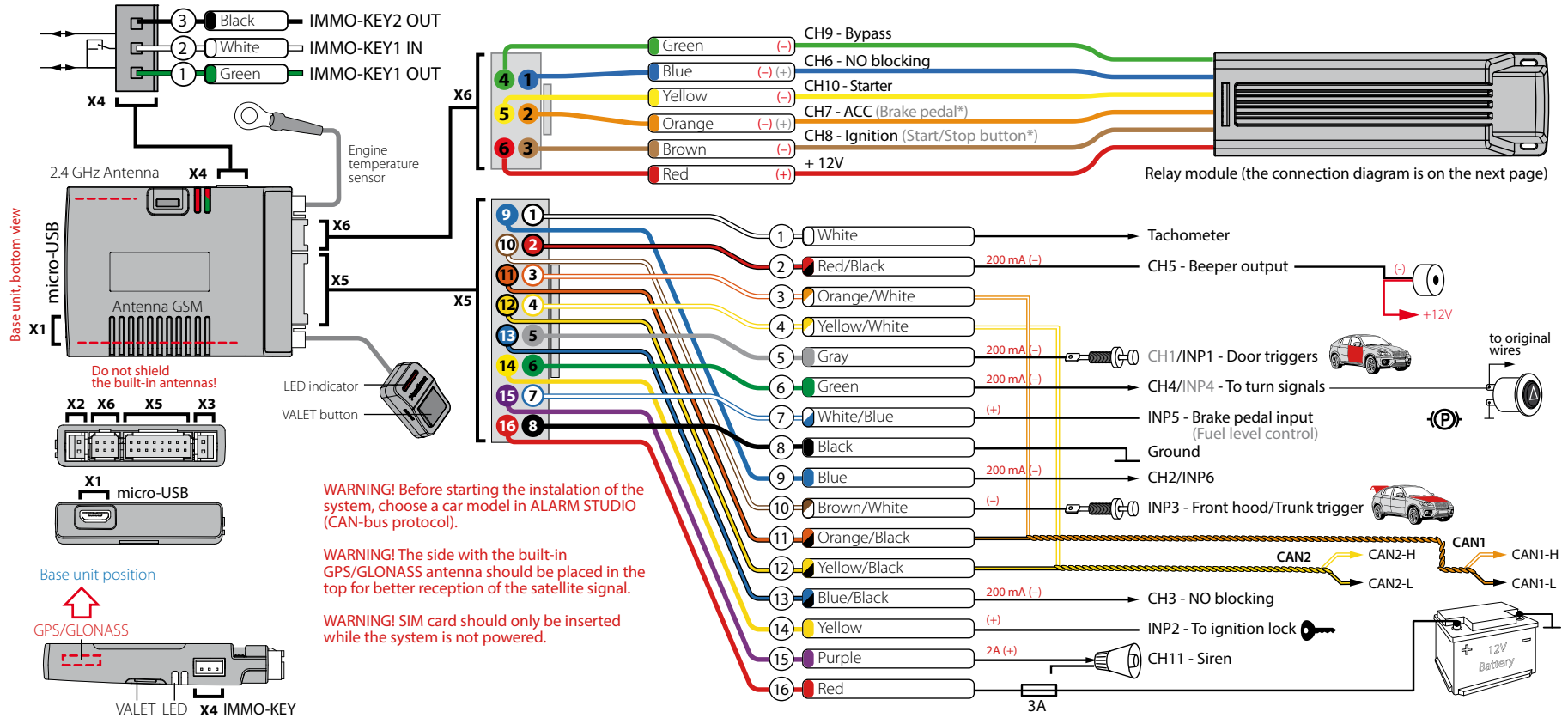

PANDECT

RMD-5M Relay module

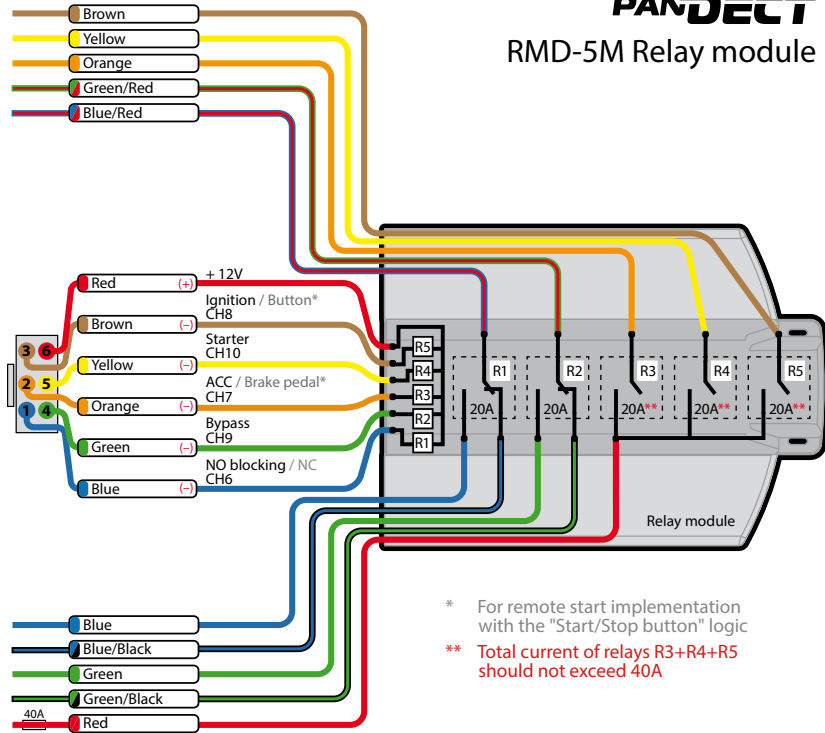

* For remote start implementation with the "Start/Stop button" logic

** Total current of relays R3+R4+R5 should not exceed 40A

WIRING DESCRIPTION

X5 socket (main socket):

- **Wire «1» (White) (Tachometer input)** — analog input of the tachometer signal, it connects to the tachometer wire or to the signal wire of a nozzle, which provide stable pulses of any polarity corresponding to the RPM.
- **Wire «2» (Red-black) (CH5)** — Factory setting is 'Beeper'. A negative output of additional channel with maximum load current 200mA. This output is multipurpose, it can operate in accordance with selected logic.
- **Wire «3» (Orange-white) (CAN1-High)** — It connects to appropriate CAN-High wire of the car.
- **Wire «4» (Yellow-white) (CAN2-High)** — It connects to appropriate CAN2-High wire of the car.
- **Wire «5» (Gray) (CH1/INP1)** — Factory setting is 'Door trigger'. This wire connects to a wire that becomes grounded when the door opens. This wire is multipurpose, it can operate as input and as output in accordance with selected logic.
- **Wire «6» (Green) (CH4/INP4)** — Factory setting is 'Control turn indicators'. This wire connects to the hazard flashers button. A negative output of additional channel with maximum load current 200mA. This wire is multipurpose, it can operate as input and as output in accordance with selected logic.
- **Wire «7» (White-Blue) (INP5)** — Factory setting is 'Brake pedal'. This wire connects to the brake pedal trigger where 12V voltage appears when the pedal is pressed (stop lights wire). Brake pedal signal is one of the system's security zones. This input is multipurpose, it can operate in accordance with selected logic.
- **Wire «8» (Black) (Ground)** — It should be connected to the car body in a grounding spot. This wire should be connected **FIRST** during installation.
- **Wire «9» (Blue) (CH2/INP6)** — Factory setting is free output. A negative output of additional channel with maximum load current 200mA. This wire is multipurpose, it can operate as input and as output in accordance with selected logic.
- **Wire «10» (Brown-White) (INP3)** — Factory setting is 'Front hood and trunk trigger'. This wire connects to appropriate wire that becomes grounded when the front hood opens. This input is multipurpose, it can operate in accordance with selected logic.

- **Wire «1» (Orange-black) (CAN1-Low)** — It connects to appropriate CAN-Low wire of the car.
- **Wire «12» (Yellow-black) (CAN2-Low)** — It connects to appropriate CAN2-Low wire of the car.
- **Wire «13» (Blue-Black) (CH3)** — Factory setting is 'Blocking N.O.'. This output is used to control blocking relay with a normally open logic (it becomes grounded on switching on the ignition when the system is disarmed; when a radio tag is in the coverage zone if the Immobilizer/Anti-Hi-Jack function is enabled). A negative output of additional channel with maximum load current 200mA. This output is multipurpose, it can operate in accordance with selected logic.
- **Wire «14» (Yellow) (INP2)** — Factory setting is 'Ignition'. This wire connects to ignition switch or to appropriate wire where 12V voltage appears when ignition is switched on. This input is multipurpose, it can operate in accordance with selected logic.
- **Wire «15» (Purple) (CH11)** — Factory setting is "Siren" It connects to the siren control wire (+) (maximum load current is 2A). This output is multipurpose, it can operate in accordance with selected logic.
- **Wire «16» (Red) (Power Supply +12V)** — It should be connected to reliable conductor with constant voltage of 12V.

X6 Socket (Relay module):

- **Wire «1» (Blue) (CH6)** — Factory setting is 'Blocking N.O.'. This output is used to control blocking relay with a normally open logic (it becomes grounded on switching on the ignition when the system is disarmed; when a radio tag is in the coverage zone if the Immobilizer/Anti-Hi-Jack function is enabled). An output of additional channel with maximum load current 250mA. This output is multipurpose, it can operate in accordance with selected logic as a negative or positive output (it depends on the settings).
- **Wire «2» (Orange) (CH7)** — Factory setting is 'ACC'. The channel is used to control accessories through an external relay. If 'Car with START/STOP button' setting is enabled, the channel will control brake pedal during remote or automatic engine start. An output of additional channel with maximum load current 250mA. This output is multipurpose, it can operate in accordance with selected logic as a negative or positive output (it depends on the settings).
- **Wire «3» (Brown) (CH8)** — Factory setting is 'Ignition'. This output is used to switch on the ignition through an external relay. It allows implementing automatic engine start, turbo timer, ignition support and connecting to ignition in series (incut). If 'Car with START/STOP button' setting is enabled, the channel

will operate in impulse mode to control the button. A negative output of additional channel with maximum load current 200mA. This output is multipurpose, it can operate in accordance with selected logic.

- **Wire «4» (Green) (CH9)** — Factory setting is 'Bypass'. Output activates during remote or automatic engine start. A negative output of additional channel with maximum load current 200mA. This output is multipurpose, it can operate in accordance with selected logic.
- **Wire «5» (Yellow) (CH10)** — Factory setting is 'Starter'. This output is used to switch on the starter of a car through an external relay. A negative output of additional channel with maximum load capacity 200mA. This output is multipurpose, it can operate in accordance with selected logic.
- **Wire «6» (Red)** — relay module power supply 12V.

X4 Socket (Multifunctional channels)

Use this socket when implementing bypass of original immobilizer using IMMO-KEY1 and IMMO-KEY2 multifunctional channels. Make connections in accordance with installation scheme. The settings of the socket are available in AlarmStudio. Disconnect the system from power supply after changing the settings.

Programming the system

Entering programming menu

To change the system settings or program the system using a computer or **VALET** button, the system should be in programming mode. Enter programming mode by entering '**Service PIN-code**' (factory preset is 1-1-1-1). PIN-code should be entered using external or located on the base unit **VALET** button. The input is indicated by flashes of external or located on the base unit LED indicator. You can enter the code only if the base unit is powered from USB socket or from external power supply, the ignition is switched off, the system is disarmed and maintenance mode is switched off.

If there is no '**Service PIN-code**', you can enter programming mode using the '**Secret PIN-code**' written on the owner's card.

Entering PIN-code:

- Enter the first digit of the code using **VALET** button. Press the button a number of times, equals to the first digit. Pauses between presses should not exceed 1 second. Each pressing will be confirmed with an orange LED indicator flash. A pause for more than 1 second and a red LED indicator flash confirm the input of the first digit. Then you can enter the next digit.

- Enter the second digit of the code using **VALET** button. Press the button a number of times, equals to the second digit. Pauses between presses should not exceed 1 second. Each pressing will be confirmed with an orange LED indicator flash. A Pause for more than 1 second and a red LED indicator flash confirm the input of the second digit. Then you can enter the next digit.

- Enter the third digit of the code using **VALET** button. Press the button a number of times, equals to the third digit. Pauses between presses should not exceed 1 second. Each pressing will be confirmed with an orange LED indicator flash. A Pause for more than 1 second and a red LED indicator flash confirm the input of the third digit. Then you can enter the next digit.

- Enter the fourth digit of the code using **VALET** button. Press the button a number of times, equals to the fourth digit. Pauses between presses should not exceed 1 second. Each pressing will be confirmed with an orange LED indicator flash. The system will confirm correct PIN-code with the series of red and green flashes and the system will enter programming mode. If the input was incorrect, it will be indicated with a red LED indicator flash and the system will stay in a previous state. New input can be attempted after 5 seconds.

Exit programming mode:

To exit programming mode turn on the ignition or turn off power of the base unit. The system will reboot programmatically (all changes will be saved) after exiting programming mode using ignition. All ways to exit the programming menu are accompanied by sound signals of the siren/Beeper and light signals of the LED indicator. Light signals indicate the number of recorded devices: first green flashes indicate the number of recorded radio tags, red flash indicates registered mobile device

Status indicator lights during PIN-code entering:

Short orange flash	Confirmation of VALET button pressing
Short red flash	Confirmation of entering a PIN-code digit
Red and green flashes	PIN-code is correct
Long red flash	PIN-code is incorrect

Preparing to program the system using a computer

The system allows programming all settings and updating software of the base unit via micro-USB cable. If the base unit has not been installed in the vehicle yet, it will be powered via micro-USB cable while programming. To program using a computer, you need a standard USB cable, a computer with Windows XP/Vista/7/8/10 and **Pandora Alarm Studio** application (you can download it from pandorainfo.com).

It is required to create an account in AlarmStudio to use **Pandora CLONE** for remote engine start (you can register without a connection to a system). **Pandora CLONE** procedure requires Internet connection.

In preparation to the programming these stages should be followed:

- connect the system and PC via USB cable;
- start Pandora Alarm Studio;
- enter the programming settings mode by entering the service PIN-code.

Updating firmware

It is recommended to update firmware of the base unit before installing and programming the system (actual version of the firmware you can download from pandorainfo.com). You can update firmware using **AlarmStudio** application after entering programming mode or using quick boot algorithm (PIN-code is not required).

Quick boot mode: open **AlarmStudio**; de-energize and disconnect the system; press and hold **VALET** button located on the base unit; release the button immediately after connecting the system and a computer via USB cable; the system will enter boot mode.

If the boot mode has been interrupted for some reason and the status indicator lights red, you need to load firmware using quick boot mode (without entering PIN-code).

Level 1	Recording radio tags into the system's memory (BT760)
Level 2	Changing the factory preset of the service PIN-code
Level 3	Recording the idle speed to the system memory
Level 4	Resetting to factory settings
Level 5	Recording Bluetooth engine compartment module (RHM-03 BT)
Level 6, 7	Recording Bluetooth radio relays №1, №2 (BTR-101)
Level 8	Recording Bluetooth GPS/GLONASS receiver (NAV-035 BT)
Level 10	Configuring system settings via the wireless interface
Level 11	Programming and configuring 'Immobilizer PIN code'
Level 15	Emergency disabling of immobilizer radio tag

Level 16	Updating Bluetooth modem firmware
Level 17	Programming bypass of original immobilizer
Level 18	Pairing and unpairing mobile device
Level 19, 20	Updating radio relays №1, №2 firmware (BTR-101)
Level 21	Updating Bluetooth engine compartment module firmware (RHM-03 BT)
Level 22	Updating Bluetooth GPS/GLONASS receiver firmware (NAV-035 BT)
Level 23, 24	Recording door sensors №1, №2 (DMS-100 BT)
Level 25, 26	Updating door sensors №1, №2 firmware (DMS-100 BT)

Enter programming mode by entering the 'Service PIN-code', Use **VALET** button to enter the desired level number (press the button a number of times, equal to level number; pauses between presses should not exceed 1 second). The system will confirm correct input with red LED flashes and short sound signals of a siren and proceed to the desired level. If the input was incorrect, the system will not confirm input and will await a new level input after a series of green and red flashes

Level 1 – Recording radio tags into the system's memory

Prepare to record all radio tags (you can record up to 3 tags), install batteries in the radio tags.

Enter programming menu and then press VALET button once. LED indicator will light green and the system will enter the tag recording mode. Tags are recorded (paired) one by one, in any order and without time limit. All previously registered radio tags will be removed when you overwrite new tags or overwrite old tags.

Recording radio tags:

Press control button on a tag and hold it for 6 seconds (6 flashes of tag status indicator), release the button after the sixth flash. If the recording was successful, a siren will emit 1 beep, after that you can move to recording the next tag

Saving changes:

To finish the recording of radio tags into the system, **VALET** button should be pressed once again, the series of red and green flashes of status LED indicator will confirm the saving.

Level 2 – Changing the factory preset of the service PIN-code

Prepare a new value of the 'Service PIN-code', it should consist of 4 digits (from 1 to 9). Write down or remember the new PIN-code.

Enter programming menu and then press VALET button twice. The system will enter 'Changing Service PIN-code' mode and the status LED indicator will turn off.

Changing the 'Service PIN-code':

- Enter the first digit of the code using VALET button. Press the button a number of times, equals to the first digit. Pauses between presses should not exceed 1 second, every pressing will confirm with orange LED indicator flash. Pause for more than 1 second and red LED indicator confirms the input of the first digit. Then you can enter the next digit.
- Enter the other numbers in the same manner. The input of the fourth number will be confirmed by series of red and green LED indicator flashes. The system will wait for PIN-code re-entering.
- Enter all four digits again;
- If you were able to correctly enter the 'Service PIN-code' twice, the indicator will produce the series of red and green flashes, new PIN-code will be recorded, the system will return to programming mode. In case of the incorrect code input the indicator will be lit red, the system will return to programming mode.

Level 3 – Recording the idle speed to the system memory

To timely turn off the starter during automatic or remote engine start via digital or analog tachometer input and the correct operation of the 'Smart Turbo Timer', it is necessary to record the engine idle speed. To record idle speed to the non-volatile system memory, enter the programming menu. Press VALET button three times. Switch on the ignition and start the engine after entering this level of programming (the engine should be warmed-up, idle speed should match the stable idle speed of the warmed-up engine). The system will confirm the presence of the idle speed status with green flashes of LED indicator. Wait until the stable idle speed will be reached and save the changes

Saving changes:

Press VALET button once to save idle speed. Successful recording of the idle speed will be confirmed with the series of red and green flashes of LED indicator. The system will exit programming menu and reboot after saving the idle speed.

Level 4 – Resetting to factory settings.

The procedure recovers the factory settings of the system without deleting previously registered devices (tags, mobile device, relays, etc.) that is stored in the non-volatile memory.

To reset the settings enter the programming mode and press VALET button four times. Press and hold VALET button for more than 4 seconds until siren sound, then release the button. The system will confirm the resetting to the factory settings with a long red flash of LED indicator. After that the system will return to a programming mode

Level 5 – Recording Bluetooth engine compartment module

To record a Bluetooth engine compartment module, enter programming mode and press VALET button 5 times. The LED indicator will light green and the system will enter the recording of an engine compartment module mode. Connect the module in accordance with installation manual. The system will confirm the registration with a short sound signal.

Saving changes:

To finish the recording of the engine compartment module, VALET button should be pressed once again, the series of red and green flashes of the status LED will confirm the saving, switch on the ignition to automatically save the settings and exit programming mode.

Levels 6, 7 – Recording Bluetooth radio relays

Radio relays recording is performed one by one starting from the 6 level: radio relay №1 is recorded on the 6 level; radio relay №2 is recorded on the 7 level. The radio relay can be overwritten only on the level of its initial registration.

To record Bluetooth radio relays №1, №2, enter programming mode and press VALET button 6 times for radio relay №1 or 7 times for radio relay №2. LED indicator will light green and the system will enter the recording of a radio relay mode. Connect a relay in accordance with installation manual. The system will confirm recording with a short sound signal.

Saving changes:

To finish the recording of the Bluetooth radio relay, VALET button should be pressed once again, the series of red and green flashes of the status LED indicator will confirm the saving, switch on the ignition to automatically save the settings and exit the programming mode.

Level 8 – Recording Bluetooth GPS/GLONASS receiver (NAV-035 BT)

To record a Bluetooth GPS/GLONASS receiver, enter programming mode and press VALET button 8 times. The LED indicator will light green and the system will enter the recording of a receiver. Connect the receiver in accordance with its installation manual. The system will confirm the registration with a short sound signal and red light of LED indicator.

Saving changes:

To finish the recording of the engine compartment module, press VALET button once, the series of red and green flashes of the status LED will confirm the saving, switch on the ignition to save the settings and exit programming mode.

Level 10 – Configuring system settings via the wireless interface

This function is under construction.

Level 11 – Programming and configuring ‘Immobilizer PIN code’

To program the «**Immobilizer PIN code**», enter the programming mode and press VALET button 11 times. The level is divided into 3 sublevels (**Sublevel 11.1 – Selecting buttons; sublevel 11.2 entering PIN-code; sublevel 11.3 – confirmation of the PIN-code input**).

The system will automatically enter the sublevel 11.1 (Selecting buttons) after entering the level 11. The system can determine buttons via analog “**Code immobilizer**” input or via digital protocol of a car.

It is necessary to configure an analog input (INP) as ‘**Code immobilizer**’ in the settings of the base unit inputs when implementing the “**Code immobilizer**” via an analog input. It may be necessary to switch on the ignition after entering the level 11 of programming (if the car bus is active only when the ignition is switched on) when implementing the “**Code immobilizer**” via digital car bus protocol.

After selecting active buttons enter the sublevel 11.2 (**Entering PIN-code**) by pressing VALET button once. Program PIN-code using selected buttons at this sublevel; press **VALET** button once and enter PIN-code again. To confirm PIN-code re-entering and save all the settings press **VALET** button once again.

Sublevel 11.1 - Selecting buttons:

This sublevel is used to select active buttons via digital protocol of a car or via ‘**Code Immobilizer**’ analog input. To determine the activity of the analog “**Code Immobilizer**” input, apply potential to the corresponding input (INP) of the base unit, LED indicator will be flashing orange.

If you determine buttons via digital protocol select one or more buttons (up to four) for entering the secret code of the immobilizer. To do this press the selected button, LED indicator will confirm input

with orange flashes. If there are no orange flashes when any button is pressed, then this button is not recognized by the system, select a different button. Repeat the procedure to select the second, third, fourth button and enter the next sublevel. To enter the next sublevel 11.2l press VALET button once.

Sublevel 11.2 - Entering PIN-code:

Program immobilizer deactivation PIN-code using selected button or buttons. Enter the first digit by pressing the previously selected button (pauses between presses should not exceed 1 second). The base unit will confirm entering with red flash of LED indicator. Enter the second (third, fourth) digit by pressing the previously selected button. The base unit will confirm entering of each digit with red flash of LED indicator.

Input the required number of digits (up to 4) and then press **VALET** button. The system will confirm receiving of the secret validator code with long red flash of **LED** indicator and will wait for confirmation of **PIN-code**.

Sublevel 11.3 - Confirmation of the PIN-code input:

11.2 Enter PIN-code again similarly to the procedure (level 11.2 – Entering PIN-code) and press VALET button. The system will confirm correct PIN-code with red and green flashes of LED indicator and will memorize PIN-code, and then the system will proceed to programming mode awaiting level input. Incorrect confirmation is indicated with long red flash of LED indicator, after that the system will return to programming mode.

Level 15 – Disabling/enabling immobilizer tag

To disabling/enabling of immobilizer tag, enter programming menu and press **VALET** button 15 times. LED indicator will light green (green light indicates enabled tag) and the system will wait for the **“Secret PIN-code”** entering. Red light of LED indicates disabled immobilizer tag.

Disabling radio tag:

LED indicator will light green after entering the programming level. The system will wait for entering the **“Secret PIN-code”**. Enter the ‘Secret PIN-code’ that is written on the owner’s plastic card. The system will confirm disabling of the radio tag with two sound signals of the siren and a long red LED flash. After that the system will return to the programming menu. If the PIN-code is not entered within 10 seconds or the input is incorrect, a siren will sound one signal, LED will produce the series of red and green flashes and the system will return to the programming menu.

Enabling radio tag:

LED indicator will light red after entering the programming level. The system will wait for action. Press **VALET** button once to enable radio tag. The system will confirm enabling with one short sound signal of a siren and a green LED light. After that the system will return to the programming menu.

Level 16 – Updating built-in Bluetooth modem firmware

Download the firmware from www.pandorainfo.com and install Pandora BT application on your mobile device (Android version 4.4 or high or iOS version 9.3.5 and higher) with Bluetooth 4.0 Low Energy or higher support).

To update firmware of the built-in Bluetooth modem, enter programming mode and press **VALET** button 16 times. Find your system in the mobile application, go to detected devices and select one of the updating option: **File manager** (for Android only) or **Internet** and update Bluetooth modem firmware. File manager allows to upload the firmware from the phone storage and Internet option allows to upload Firmware from the server to the base unit.

Level 17 – Programming bypass of original immobilizer

Bypass learning procedure is performed on this level. A detailed manual can be found in installation scheme for a car in AlarmStudio.

Enter programming mode and press **VALET** button 17 times. LED indicator will be lit green. If system installation was performed correctly on successful engine start using a key, LED indicator will flash green. After completing of the procedure, a siren will emit a short sound signal and LED indicator will light green. If the learning procedure finishes with an error, LED indicator will light red.

Saving changes:

To finish the learning procedure, switch on the ignition and press **VALET** button. The system will return to programming mode.

Level 18 – Pairing and unpairing mobile device

The system supports only one mobile device. Pairing of a new mobile device (if the system has previously paired device) is not allowed without unpairing procedure. When you overwrite the same device in the system memory, you should delete the Bluetooth connection on your mobile device, delete the mobile device from the system memory and then pair the mobile device in the system memory.

To pair a mobile device, enter the programming mode and press **VALET** button 18 times. LED indicator will light green (green light indicates the system is ready to pair a mobile device) and the system will enter the mobile device pairing mode. Red light of LED indicates the system has already had registered mobile device, overwriting of mobile device can be done only after unpairing procedure.

Pairing mobile device:

LED indicator will light green after entering the level. Open ‘Pandora Online’ mobile application, go to ‘Bluetooth Control’ -> ‘Not specified’ menu (‘Bluetooth device’ for iOS). This setting will be available after adding the system in the account. The application will search for the system via Bluetooth connec-

tion. Select the found system, the system and the mobile device will be automatically paired. The system will confirm the pairing with a sound signal of a siren and red light of LED indicator.

Unpairing mobile device:

LED indicator will light red after entering the level. Press **VALET** button and hold it for more than 4 seconds, release the button. The system will confirm deleting with the series of sound signals of a siren and the system will return to mobile device registration mode (LED indicator will light green).

Saving changes:

To finish the registration of a mobile device, **VALET** button should be pressed once, the series of red and green flashes of the status LED indicator will confirm the saving, switch on the ignition to automatically save the settings and exit the programming mode.



WARNING! IF THERE IS NO AUTOMATIC PAIRING, ENABLE 'PIN REQUEST FOR PHONE PAIRING' ITEM IN THE 'RADIO TAG AND MOBILE DEVICE FUNCTIONS' SETTINGS AND MAKE PAIRING PROCEDURE AGAIN. THE MOBILE DEVICE WILL REQUEST PIN-CODE (0-0-1-1-1-1)

Level 19, 20, 21, 22, 25, 26 – Updating firmware of additional Bluetooth devices

Download the firmware from www.pandorainfo.com and install Pandora BT application on your mobile device.

To update firmware of additional devices, enter the programming mode and press VALET button the number of times equals to the desired level number (see the Programming levels table). Find your system in the mobile application, go to detected devices and upload the previously downloaded firmware to the system.

Level 23, 24 – Recording door sensors №1, №2 (DMS-100 BT)

3Door sensors recording is performed one by one starting from the 23 level: A door sensor №1 is recorded on the 23 level; a door sensor №2 is recorded on the 24 level. A door sensor can be overwritten only on the level of its initial registration. To record door sensors №1, №2, enter programming mode and press **VALET** button 23 times for the door sensor №1 or 24 times for the door sensor №2. LED indicator will light green and the system will enter the recording of a door sensor mode. Insert the battery into the sensor. The system will confirm recording with a short sound signal.

Saving changes:

To finish the recording of the Bluetooth radio relay, press **VALET** button once, the series of red and green flashes of the status LED indicator will confirm the saving, switch on the ignition to save the settings and exit the programming mode.

Additional device

Blocking radio relay BTR-101

Blocking BTR-101 radio relay is optionally available for Bluetooth systems. Blocking radio relay with built-in accelerometer should be placed in the engine compartment. Herewith zone of built-in aerial 2,4 GHz should not be shielded. Provide a rigid fastening to the car body or to the fixed wirings. It is forbidden to hide the module in wiring. To save energy, radio relay power is connected to the ignition. Radio relay is normally closed and has a full set of contacts. Blocking is carried out on unauthorized movement.

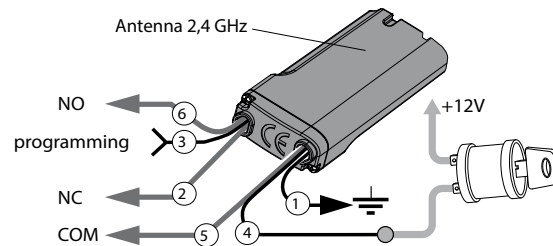

WARNING! DO NOT PLACE RADIO RELAYS DIRECTLY ON THE ENGINE!

Radio module of engine compartment RHM-03 BT

This module is designed to simplify the system installation and wiring in the engine compartment module. Data transmission and control are performed via system standard 2.4 GHz radio channel with Bluetooth 4.2 Low Energy protocol. The module allows to control front hood locks, siren and digital engine preheater it also allows to block the engine (engine blocking can be activated immediately or when determining motion with built-in accelerometer, it depends on the system configuration). The module also sends information about the temperature to the base unit.



Radio module of engine compartment RHM-03 BT

Control devices



Radio tag BT-760

Siren sounds and turn light signals

Signal name	Signal description
Alarm mode, PANIC mode	Incessant sound and light signals for 30 sec
Arming	1 sound and 1 light signals
Disarming	2 sound and 2 light signals
'Sensors triggered' signal when disarming	4 sound and 4 light signals
'Sensor malfunction' signal when arming	4 sound and 4 light signals
Sensor warning level triggered	3 sound signals
Car search	5 sound and 5 light signals

Beeper sound signals

Signal name	Signal description
Enable the maintenance mode	1 sound signal
Disable the maintenance mode	2 sound signals
A battery in the radio tag is discharged	3 sound signals / 3 times
Absence of the radio tag	5 sound signals / 5 times
Blocking warning	Fast sound singals

Meaning of indicator LED colors

Indicator status	Meaning
Short red flashes	The system is armed
Lit red	The system is preparing for automatic arming
Orange flash	Confirms VALET button press
Green flashes	Confirms a number of recorded remotes (when switching on ignition)
Red flash	Confirms a recorded mobile device (when switching on ignition)
Red and green flashes	PIN-code confirmed
Faded	The system is disarmed

Checking the number of registered radio tags/mobile devices

The number of recorded tags and mobile device can be checked by the number of green and red flashes of LED indicator. Number of registered tags can be checked every time the ignition is switched on when the system is disarmed. Number of green LED flashes will indicate the number of recorded tags, following red flash will indicate registered mobile device.

You can also check the number of recorded tags and registered mobile device by taking off and putting back on battery terminal. The system will emit short sound signals from a siren with less than 1 sec. interval. The number of the signals equals to the number of recorded tags. After a pause of 2 seconds the system signal will indicate registered mobile device.

System modules layout

Ask the installer to mark system's modules on the picture provided. This information can be important for diagnostics in case system malfunctions.

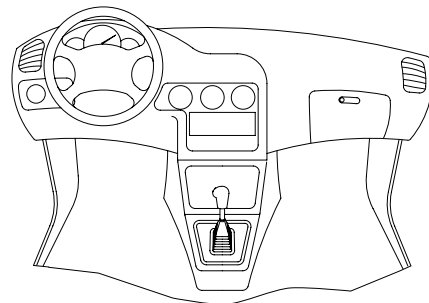

- 1 Base unit
- 2 Valet button
- 3 Blocking radio relay
- 4 LED indicator
- 5 Automatic start module
- 6 GPS-receiver

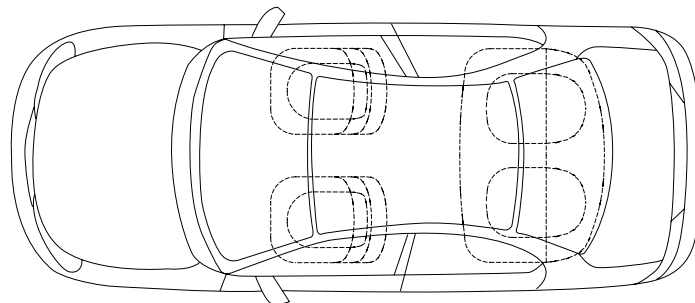

Warranty obligations

Manufacturer guarantees correct operation of the service-security system if exploitation, installation, storage and transportation conditions described in this manual were met.

The system should only be used according to installation scheme and user manuals. The system is meant to be installed by the professional car electronics installers. We recognize that outside Russia the system can be installed by amateurs – those installations are still a subject of limited warranty. The installer should fill in installation certificate that is included in this manual.

Parts malfunctioning during warranty period on the fault of the manufacturer should be repaired or replaced by the installation center of the manufacturer or by certified service center. List of certified service centers outside Russia can be found on pandorainfo.com

The user loses the right for warranty services in the following cases:

- when warranty period expires;
- if exploitation, installation, storage or transportation conditions were not met;
- if there is mechanical damage of the external parts of the system after it is sold. This includes: fire damage, consequential damage in case of car accident, aggressive liquids and water seeping damage, damage caused by improper use;
- if the damage was caused with incorrect settings and parameter adjustment;
- if system devices are replaced with any devices that are not recommended by the manufacturer;
- if manufacturer sealing is broken;
- if there is no properly filled warranty card and installation certificate.

Warranty period is 3 years since the moment of purchase, but no more than 3,5 (three and a half) years since the moment of production.

This warranty does not include batteries of the remotes, as they have their own service life time. Maintenances and repairs of the system with expired warranty period are carried out at the expense of the user on separate contracts between the user and the installer/service center.

Transportation rules

Products should be transported in the original packaging by any means of transport as long as they are protected from mechanical damage and precipitation. Packaged products should be stored on racks in piles of 6 or less boxes, in enclosed, dry, heated rooms (no less than 1m from heating) which exclude possible interaction with moisture, oil products and damaging environmental factors.



WE RECOMMEND YOU TO FILLING OUT INSTALLATION CERTIFICATE AND WARRANTY CARD BY INSTALLER. THESE DOCUMENTS MAY BE REQUIRED FOR CONTACTING CUSTOMER SUPPORT.

INSTALLATION CERTIFICATE

I, the undersigned _____

Position, name.

professional installer, certify that installation of the service-security system, specified below, was carried out by me in accordance with manuals and schemes provided by the manufacturer.

Car specifications:

Car model _____ Type _____

Id number (VIN) _____

Registration number _____

Security system specification:

Model Pandora DXL 1940L

Serial number _____

Service center name, full address and installer's stamp

Signature _____/_____/_____

Signator

Work accepted _____/_____/_____

Signator

Date « ____ » _____ 20__ year.

ACCEPTANCE CERTIFICATE

Model Pandora DXL 1940L is in conformity with Electromagnetic Compatibility Directive EMC 2004/108/EC and R&TTE Directive 1999/5/EC.

Serial number _____ Date of production _____

Responsible person's signature (stamp)

Packager _____

Signature (personal stamp)



WARRANTY CARD

Model Pandora DXL 1940L

Serial number _____

Date of purchase « ____ » _____ 20 ____ year

Seller's (installer's) stamp

Seller's signature

