



Pandora would like to thank you for choosing
our Pandora Professional service and security
system



pandorainfo.com
contact@pandorainfo.com

Made in Russia
20a, Kirova str., Kaluga, Russia

Pandora is a brand of Russian Experimental Engineering Factory, a full production cycle electronics R&D facility. We design and produce car service-security systems for more than 10 years and have reached a considerable success on Russian and post-communist markets – biggest security system markets in the world. Our systems are made to withstand severe weather conditions and criminal situation of northern Eurasia.

Your car controls and monitoring options at your fingertips

Pandora Professional is a premium-class telemetric service and security system. Elegant and advanced technical design and unique ergonomic interaction algorithms allow enhancing your car with fantastic set of intuitive and useful functions. With Pandora Professional your car will have an unmatched level of security and service.

EXCLUSIVE FEATURES OF PANDORA PROFESSIONAL



WARNING!

Installation should only be carried out by certified Pandora installer. In case a certified installer is not available, installation should be carried out by a professional car electric using AlarmStudio software, provided schemes and common sense. Custom installations by non-certified entities may lead to malfunctions that will not be accepted for repairs on terms of warranty. Most features are highly dependent on competent installation. Our systems are thoroughly tested for quality, so if a feature fails to produce expected results, most likely the problem is in improper installation.

This device has limited external factors resistance. It should not be subjected to water beyond occasional splatter, or operated in temperatures outside -40 to +80°C range.

- Online service pro.p-on.ru allows monitoring, controlling, and adjusting parameters of your car using any computer or smartphone with Internet connection.
- SOS emergency button on the remote and automatic notification system will be of help in any situation that threatens your personal security. It is not just the car we aim to protect.
- Active security mode will constantly monitor your car GPS coordinates and GSM connection.
- GPS/GLONASS tracking allows access to information about your car's traveled path, speed and various other data.
- Interior microphone that can be accessed from your phone.
- Infinite event history with coordinates, precise time and full information about car's condition.
- Pandora Pro and Pandora Online mobile apps to control your security system via smartphone and to access online service pro.p-on.ru are available for iOS and Android. You can download Pandora Pro from AppStore or Pandora Online from Google Play and test them in demo mode.
- Wide range of automatic engine start options: by weekdays, by engine or interior temperature, by battery voltage to keep it charged, etc.

It is essential for systems functioning that you read and understand instructions in this manual. Note that all radio devices are subject to interference, which could affect proper performance.

IMPORTANT! Note that this manual describes remote and manual functions for the most part. Functionality of the system is vast and would require a book-sized manual to fully describe. Instead we use a handy software named AlarmStudio that functions as both programming tool and an extended installation & functionality manual. It requires Windows and can be downloaded at pandorainfo.com

Product is in conformity with Electromagnetic Compatibility Directive EMC 2004/108/EC and R&TTE Directive 1999/5/EC



Table of contents

Section 1.	9	System features
General information	12	System set
Section 2.	13	Main control remote with LCD
Control remotes	14	Quick access functions of the main control remote
	16	Supplementary control remote (three-button)
	17	Light indicator signals
	17	Icons of remote
	20	Arming procedure
	21	Disarming procedure
	22	Unlocking the trunk
	23	Locking/unlocking doors when the engine is running
	24	Car search function
	25	Delayed arming (Hands Free mode)
	26	PANIC mode
	26	CHECK mode, monitoring car parameters
	27	Event history

**Section 2.
Control
remotes**

28	Remote and automatic engine start
29	Programmable neutral procedure
30	Remote engine start
31	Remote engine stop
32	System settings menu
32	Main settings menu
33	Automatic engine start settings
36	Engine preheater controls
37	Settings of the sensors
43	Tracking options
43	Siren signal options
44	Hands Free mode settings
44	Setting of the time channels
45	Switching on/off GPS/GLONASS receiver
45	Switching on/off GSM modem
46	Maintenance/valet mode
47	Settings of the remote
52	Checking the number of recorded remotes
52	Charging the remote

**Section 3.
Immobilizer and
owner's personal
safety**

53	Immobilizer mode
54	Antihijack mode
54	Replacing immobilizer tag battery
55	Immobilizer code using original car controls
55	PANIC (SOS) button
55	Emergency numbers settings
56	Automatic emergency notifications

**Section 4.
Pandora
and phone**

57	Phone notifications
57	Security zones triggered notifications
58	Receiving voice information via phone
59	Control over system via phone
65	Changing core settings via phone

**Section 5.
Pandora online
information service
pro.p-on.ru and
mobile apps**

71	System login
72	Event history
73	System status information
74	Security and warning zones
75	Car movement history (tracking)
76	Smartphone apps

**Section 6.
Control in case of
emergency**

77	Control over system in case of emergency, entering individual PIN-code
----	---

**Section 7.
Any problem can be
solved**

79	Any problem can be solved
----	---------------------------

Section 8.
**Important
Information**

81	Siren sounds and turn light signals
82	Meaning of indicator LED colors
83	Glossary of terms
86	System modules layout
88	Warranty obligations
90	Installation certificate
91	Acceptance certificate
91	Warranty card



General information

1

SYSTEM FEATURES

- Main LCD remote**
- Arming and disarming security system using separate buttons.
 - Controls status of 12 independent security zones.
 - Vibrating alert.
 - 16 notification ringtones.
 - Automatic LED lighting of the LCD.
 - Vibration confirmation of the button press.
 - Battery level indicator.
 - Current time indication, alarm clock.
 - Time synchronizes with the base unit for exact time stamp in the event history.
 - Engine and interior temperature, voltage indication.
 - Prompt remote access to the settings of shock, motion, tilt and supplementary sensors.
 - View last 48 hours of the event history with time stamps.
 - Automatic control of RF coverage zone and notifications.
 - Dialog encryption of commands.

- Base unit**
- Individual 128-bit encryption key.
 - Online information service that stores infinite event history, car path monitoring and control over main functions.
 - Voice interface for controlling the system using a phone.
 - Individual disarming PIN-code.
 - Event history that is stored in the base unit with date, time and coordinates.
 - RC blocking relay (2,4 GHz, frequency, up to 3 units can be connected).
 - Built-in integral accelerometer for determining motion and shocks with adaptive processing algorithm and sensitivity controls via the remote.
 - External dual-band GSM 900/1800 MHz aerial.
 - Built-in 2,4 GHz aerial.
 - Monitoring of on-board voltage.
 - Advanced process of sensor data reading, eliminating false alarm possibilities.
 - Precision measurement of interior and engine temperature, displayed on the remote.
 - Sequential unlocking of the doors.
 - Arming when the engine is running.
 - Automatic arming.
 - Registers delay for interior lighting when arming.
 - Hands Free mode for arming/disarming without using a remote.
 - Software updates via built-in mini-USB socket.

- RF module**
- 'CALL' button for calling the driver.
 - LED status indicator.
 - Built-in sound emitter.

Car security zones Pandora Professional service-security system guards following independent zones with corresponding zone notifications on the remote, and recording alarms into the event history:

- car doors perimeter (separately for every door)
- front hood triggers
- trunk triggers
- ignition trigger
- break pedal button
- triggering of the shock sensor (warning level)
- triggering of the shock sensor (alarm level)
- triggering of the motion sensor
- triggering of the two-level supplementary sensor (warning level)*
- triggering of the two-level supplementary sensor (alarm level)*
- critically low on-board voltage
- marker lights left on notification when arming**

* Volume sensor is not a part of Pandora Professional service-security system set.

** Availability of this function depends on car make and model.

All alarm events are recorded into system's non-volatile memory with coordinates, date and exact time the event happened. Event history is accessible on user individual page of online service pro.p-on.ru and can be read using a remote or a computer connected to the base unit via mini-USB cable.

SYSTEM SET

1.	Base unit	1
2.	RF module and cable	1
3.	Main control remote with LCD	1
4.	Additional remote (three-button)	1
5.	Immobilizer tags	2
6.	Leather case for immobilizer tags	1
7.	GPS receiver	1
8.	Blocking radio relay	1
9.	External dual-band GSM 900/1800 MHz aerial	1
10.	Relay automatic start module	1
11.	Main cable	1
12.	Supplementary cable	1
13.	Cable with VALET button and three-colored light indicator	1
14.	Siren	1
15.	Mini-USB cable	1
16.	Microphone	1
17.	Supplementary sensor socket with a wire	1
18.	Limit switch and wire	2
19.	Tapping screw Ø 4,2x13	5
20.	Plastic tie 120 – 150 mm	2
21.	Grounding contact	3
22.	User manual	1
23.	Installation manual (connection scheme)	1
24.	Plastic card with individual secret code	1
25.	Packaging	1
26.	CR-2032 battery	2

Manufacturer reserves the right to change set and construction of the product to improve its technological and operational parameters without notification.

Pandora







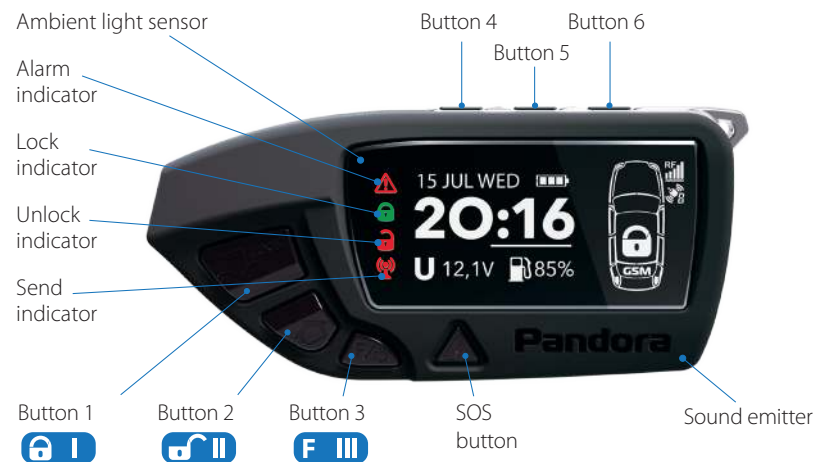

Control remotes









2

MAIN CONTROL REMOTE WITH LCD



QUICK ACCESS FUNCTIONS OF THE MAIN CONTROL REMOTE

	System disarmed		System armed
	Engine is running	Engine is stopped	
 I (short press)	Lock doors without arming	Arming with sound confirmation	Search mode – car will flash turn signals and sound horn for 5 seconds
 I (1 sec.)		Arming without sound confirmation	Search mode – car will flash turn signals without any sounds for 5 seconds
 I (2 sec.)	Switch on ignition support		
 II (short press)	Unlock doors	Unlock doors and disable immobilizer	Disarming with sound confirmation
 II (1 sec.)		Unlock doors and disable immobilizer	Disarming without sound confirmation
 II (> 2 sec.)	Switch off ignition support		Switch off ignition when turbo timer, remote or automatic engine start is active
 III (short press)	Switch on LCD lighting*		
 III (1 sec.)	Switch on/off timer channel (CH1) Unlock trunk (CH1)		

 III (2 sec.)	Switch on/off additional F button function		
 III (3 sec.)	Switch on/off the remote*		
Button 4 (1 sec.)	Emergency call*		
 I +  II (short press)	PANIC mode		
 I +  III (short press)	Arming when the engine is running with sound confirmation	Arming in 30 seconds (Hands Free mode) with sound notification	
 I +  III (1 sec.)	Arming when the engine is running without sound confirmation	Arming in 30 seconds (Hands Free mode) without sound notification	
Button 6 (1 sec.)	Request current car status (CHECK command)*		
Button 6 (2 sec.)	Enter event history*		
Button 6 (3 sec.)	Force connection to the online service		
Button 5 (1 sec.)	Settings menu		
Button 5 (2 sec.)	Switch on engine preheater		
Button 5 (3 sec.)	Switch off engine preheater		

* Available only on the remote with LCD.



WARNING! All control commands are transmitted via radio channel, for maximum effectiveness and range it is recommended not to shield aerial area (see picture) with fingers when using a remote.

Two-way remote is the main mean of control over the system. For easily distinguishable notifications the remote uses 16 ringtones. Each ringtone matches particular event.

Remote has flashing LED indicators for additional information. Occasional green flashes mean that there is a connection and there were no alarm events, red flashes mean that either an alarm even happened, there is no connection to the base unit, or the system is not armed.

The remote is fully operational when shipped. To switch the remote on, press and hold **F III** button for 3 seconds. **'Rem ote on'** ringtone will play. Pressing and holding this button again for 3 seconds will cause the remote to switch off.

SUPPLEMENTARY CONTROL REMOTE (THREE-BUTTON)



LIGHT INDICATOR SIGNALS

Red Alarm indicator

Flashes occasionally and sounds additional short signal once a minute until any button is pressed, after the end of any alarm notification.

Green Lock indicator

Flashes occasionally if system is armed and there is a connection.

Red Unlock indicator









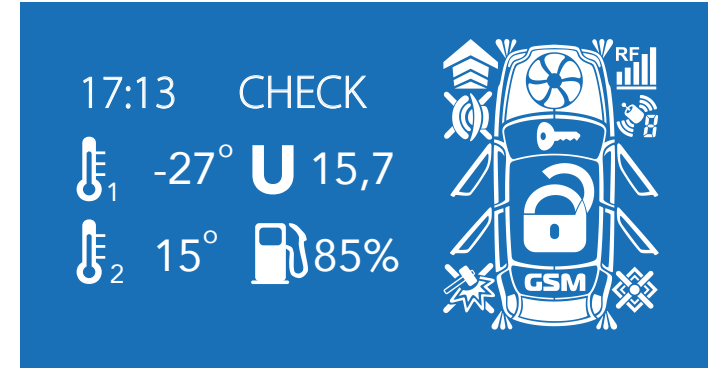









Flashes occasionally if system is not armed.







Red Send indicator

Flashes occasionally if there is no connection.

ICONS OF REMOTE



1.  Flashes if there is no connection to the base unit.
2.  Flashes when transmits or receives commands.
3.  GSM modem. The icon will be lit if the GSM modem is switched on and the car is in the coverage area of the cellular network. The icon flashes if there is no GSM connection.
4.  GPS receiver. The icon will be lit if the GPS receiver is switched on and receiving coordinates of the car. The icon flashes if it is not possible to receive the coordinates of the car.
5.  Security mode status (Armed/disarmed).
6.  Shock sensor security zone.
 -  Warning level of the sensor.
 -  Alarm level of the sensor.
 -  Warning level zone monitoring disabled.
 -  Shock sensor monitoring disabled.
7.  Trunk security zone.
8.  Engine operation icon.
9.  Light signalization (using marker lights, turn signals).
10.  Front hood security zone.
11.  Motion sensor security zone.
12.  Silent mode of the system.
 -  Warning signals of the system disabled.
 -  All sound signals disabled.

13.  Ignition, ignition security zone.
14.  Door security zone. Separate for each door.
15.  Supplementary sensor security zone.
 -  Warning level of the sensor.
 -  Alarm level of the sensor.
 -  Warning level zone monitoring disabled.
 -  Supplementary sensor monitoring disabled.



with sound confirmation



without sound confirmation

press and hold 1 sec.



doors locking • system arming

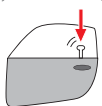

1x
1 flash



1 flash



ARMING PROCEDURE

Arming the system allows monitoring of all security zones, locks the doors and blocks the engine.

To arm the system when the engine is stopped, shortly press button on the remote. The siren will sound and turn signals will flash once. The remote will play 'Arming' ringtone and security mode status icon (the lock) will change to: .

For arming without sound confirmation press for more than 1 second. If hood or trunk were open when arming doors, the siren will sound 4 short signals instead of 1, turn signals will flash 4 times, remote will play 'Warning!' ringtone and will show troubled zone. This zone sensor will be disabled at that moment. Sensor will be armed again in 15 seconds after the zone was set right.

1 * – Arming using a phone.



with sound confirmation



without sound confirmation

press and hold 1 sec.



doors unlocking • system disarming

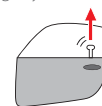

1x
2 flashes



2 flashes



DISARMING PROCEDURE

To disarm the system, shortly press button on the remote. The system will confirm with 2 short siren signals and 2 flashes of turn signals. The remote will play 'Disarming' ringtone and security mode status icon will change to: .

For disarming without sound confirmation press button for more than 1 second.

If there were new alarm events during time the system was armed, siren will sound 4 times and turn signals will flash 4 times, the remote will sound 'Warning' ringtone and will indicate zones triggered. Detailed event history can be accessed by using CHECK button.

When disarming, two-step mode of unlocking the doors can be programmed. First press will disarm the system and unlock driver's door while second press will unlock all the other doors.

0 * – Disarming using a phone.



UNLOCKING THE TRUNK

To independently unlock the trunk, no matter if the system is armed or not, press **F III** button and hold it for 1 second.

If the system is armed when this action is performed, the trunk will be disarmed, shock and supplementary sensors of the trunk will be disabled. All the other security zones will remain armed.

If the trunk was not opened in 15 seconds after using 'Unlock trunk' command, the system will lock it back, enable sensors and arm trunk security zone. This procedure will be confirmed with 1 flash of turn signals.



LOCKING/UNLOCKING DOORS WHEN THE ENGINE IS RUNNING

The system controls doors locking/unlocking: locking them when arming and unlocking when disarming.

There is an automatic movement lock mode that will lock the doors at the car movement and will unlock them when the ignition is being switched off. In no less than 5 seconds after ignition was switched on, the doors will be locked automatically when the car starts moving, and unlocked when the ignition is switched off (programmable). If any door was opened after the ignition had been switched on, automatic locking will be disabled to prevent locking the keys inside the car.

Locking and unlocking doors when the engine is running can be forced using a remote. To do this, shortly press **A I** when the engine is running. Pressing **A II** button will unlock the doors in the same way.

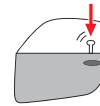

locking doors

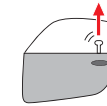

unlocking doors





◀ CAR SEARCH FUNCTION

To easily find your car on a massive parking, shortly press **L I** when the car is armed. The system will sound the siren and flash turn signals 5 times in a row.

To search for car without sound confirmation, hold **L I** button for more than 1 second.

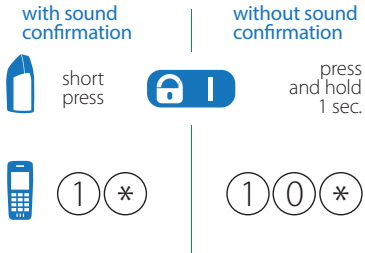

30 sec.

doors locking • system arming

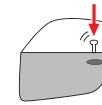

◀ DELAYED ARMING (HANDS FREE MODE)

If when leaving the car you cannot arm it using a remote (you have your hands full), you can use **delayed arming**.

To activate this mode, shortly press **L I** and **F III** simultaneously. The siren will sound and turn signals will flash once, indicating that the mode is triggered. LCD remote will display **AUTO** icon and LED indicator will be lit red. In 30 seconds the door will be locked and the system will be armed. This procedure will be confirmed with 1 sound signal of the siren and 1 flash of turn signals.

To activate this mode without sound confirmation, press and hold both **L I** and **F III** for more than 1 second.

To cancel delayed arming when it is triggered, simply press **L I**.



◀ PANIC MODE

If your car or you are in danger and you want to draw attention to your car, you can use **PANIC mode**. In this mode the siren will sound and turn signals will flash repeatedly.

To trigger PANIC mode, press **F I** and **F II** simultaneously. To switch it off, press either **F I** or **F II**.



◀ CHECK MODE, MONITORING CAR PARAMETERS

To receive information about engine temperature, interior temperature and on-board voltage, press button 5.

For 10 seconds, numeric indicator will be sequentially showing interior temperature (), engine temperature () and battery voltage ().

To exit this mode, shortly press **F III** button, otherwise it will end automatically in 10 seconds.

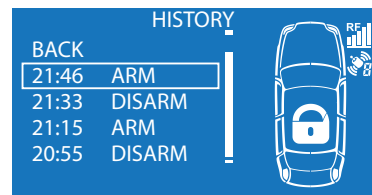
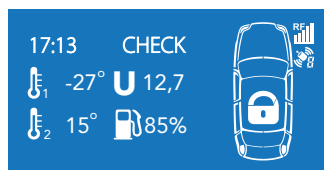

◀ EVENT HISTORY

To access event history into the system's memory, press and hold button 6 for 1 second.

Navigate last 48 events using button 6 (forward) and button 4 (back). Events are displayed by showing time of the event and flashing corresponding indicators. Mnemonic progress bar displays event's ordered number in history.

To exit this mode, press and hold **F III** for 1 second, otherwise the mode will be exited in 60 seconds.

0 9 * – Listen to the extended event history using a phone.

REMOTE AND AUTOMATIC ENGINE START



WARNING!

Only enable remote start if your local legislation allows driverless cars to have working engine.

The system allows for **remote engine start** using remote engine start command or **automatic engine start** using preconfigured automatic engine start function. Remote start can be used to heat engine and interior, charge battery or to cool the interior with air conditioning.

Remote and automatic start can only be used when the system is armed.

If the car has manual transmission, automatic start will only occur if **programmed neutral** function was enabled when the car was arming.

Remote and automatic engine start on automatic transmission cars will only occur, if transmission selector lever was left in a 'P' position.

When using remote and automatic engine start functions, make sure that the car is secured with handbrake or some other means of fixating the car on a parking position.

While system is in remote and automatic start mode, it keeps performing all security functions save for shock sensor, which will be disabled. To compensate, motion sensor sensitivity, responsiveness and range will be increased. If any security zone is triggered, the engine will be immediately stopped and alarm mode will be entered. Herewith all engine blocking will be activated.

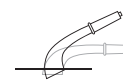

fixate the car using a handbrake



press and hold 3 sec.



leave the car, close the doors







press and hold 3 sec.



the engine will be stopped, the system is ready to perform remote start





PROGRAMMABLE NEUTRAL PROCEDURE

If you are planning to use remote and automatic engine start on a car with manual transmission, you will need to perform following actions before arming:

1. When the engine is running, fixate the car with the handbrake.
2. Press and hold  button for 3 seconds.
3. Turn the key in the ignition lock to the **OFF** position (**while you are doing it the engine should be running**) and take it out of the lock.
4. Leave the car, close the doors.
5. Press  button to arm the car and lock the doors. On LCD remote the engine operation icon  will be spinning and security mode status icon  will light.
6. The engine will be stopped. Now the system is ready to perform remote and automatic engine start.



◀ REMOTE ENGINE START

If the system is prepared for remote start, to execute it, press and hold  for 3 seconds. Sound signal will confirm the command, LCD will show crossed out shock sensor icon  and flashing engine operation icon  signifying preparation to the engine start. In a few seconds the engine will be started, the remote will play **'Engine start'** ringtone and show spinning engine operation icon .

Engine operation duration depends on system settings – either heating time or threshold temperature for engine stop.

 ①②③* – Remote engine start using a phone.

If the engine was started using remote or automatic start (via timer of clock), 123* phone menu command will extend its operation period by 10 minutes.



press and hold  for 3 sec.



preparing to start

 + 4 flashes





engine start



 'engine start' ringtone



◀ REMOTE ENGINE STOP

To remotely stop the engine while it performs heating, press and hold  for 2 or more seconds. The engine will be immediately stopped and it will be confirmed by remote playing **'Engine stop'** ringtone and engine operation icon  fading.

The remote will give notification 1 minute before designated engine stop:  icon will flash and **'Engine stop in 1 minute'** ringtone will play every 10 seconds.

If the engine was started using remote or automatic start, remote engine start command will extend its operation period by 10 minutes. This procedure can be repeated multiple times.

 ③②①* – Remote engine stop using a phone.



 'engine start' ringtone



press and hold  2 sec.



 'engine stop' ringtone



engine stopped

SYSTEM SETTINGS MENU ▶

Main system parameters and settings can be changed using LCD remote. To enter the settings menu, press and hold button 5 for 1 second. LCD will display MAIN SETTINGS MENU with the list of available functions.

To cycle between sub-levels of settings, use buttons 4 and 6, to enter a sub-level of settings, press and hold button 5 for 1 second.

To exit a sub-level, select the topmost option and press button 5.

To exit any level of the menu without saving, press button **F III**. To save particular changes, select SAVE using buttons 4 and 6, then press button 5 to confirm.

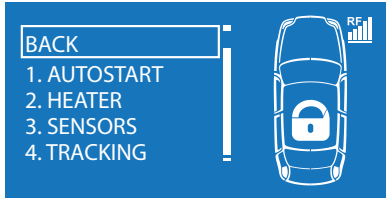

◀ MAIN SETTINGS MENU

After holding button 5 for 1 second, LCD will display a list of available functions.

Button 5 (1 sec.) >>>

1. AUTOSTART – automatic engine start options
2. HEATER – engine preheater control
3. SENSORS – settings of the sensors
4. TRACKING – enable or disable tracking function
5. SIREN – setting for the siren sound signals
6. HANDS FREE – Hands Free options
7. CHANNELS – control over timer channels
8. GPS RECEIVER – switching on/off GPS/GLONASS receiver
9. GSM MODEM – switching on/off GSM modem
10. VALET MODE – switching on/off maintenance/valet mode
11. SETTINGS – settings of the remote
12. INFORMATION – software version information

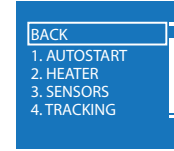

short
press

6

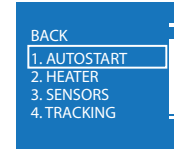

short
press

5

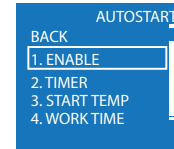

◀ AUTOMATIC ENGINE START SETTINGS

The system allows setting up modes of automatic engine start and stop. Synchronized real-time clock on the remote and base unit and other autonomous system settings allow many engine start options without needing to have the remote in command radio range.

To enter automatic engine start settings menu, select AUTOSTART option in the main menu using buttons 4 and 6, then select this option with button 5 short press. Following functions will be displayed:

1. ENABLE – switching on/off automatic engine start
2. TIMER – time settings for automatic engine start
3. START TEMP – temperature settings for automatic engine start
4. WORK TIME – max engine work time settings for automatic engine start
5. PERIODICALLY – settings of periodical engine starts
6. STOP TEMP – engine stop temperature settings

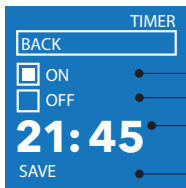

- switching on engine start by time
- switching off engine start by time
- set automatic engine start time
- save settings

Time settings for automatic engine start

To set time for automatic engine start, select TIMER menu using navigation buttons (4 and 6) and confirm it with button 5 short press.

Full path to this settings menu:
MAIN MENU >> 1. AUTOSTART >> TIMER

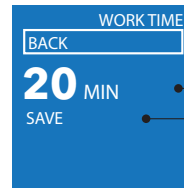

- set engine work time in minutes
- save settings

Max engine work time settings for automatic engine start

To set max engine work time for automatic engine start, select WORK TIME menu using navigation buttons (4 and 6) and confirm it with button 5 short press.

Full path to this settings menu:
MAIN MENU >> 1.AUTOSTART >> WORK TIME

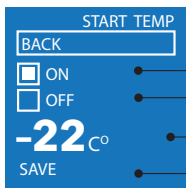

- switching on engine start by temperature
- switching off engine start by temperature
- set automatic engine start temperature
- save settings

Temperature settings for automatic engine start

To set temperature for automatic engine start, select START TEMP menu using navigation buttons (4 and 6) and confirm it with button 5 short press.

Full path to this settings menu:
MAIN MENU >> 1. AUTOSTART >> START TEMP

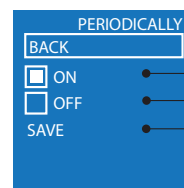

- switching on periodical engine starts
- switching off periodical engine starts
- save settings

Settings of periodical engine starts

To configure periodical engine starts, select PERIODICALLY menu using navigation buttons (4 and 6) and confirm it with button 5 short press.

Full path to this settings menu:
MAIN MENU >> 1.AUTOSTART >> PERIODICALLY

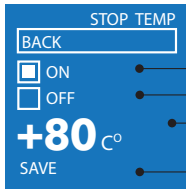

- switching on engine stop by temperature
- switching off engine stop by temperature
- set engine stop temperature
- save settings

Engine stop temperature settings

To set engine stop temperature, select STOP TEMP menu using navigation buttons (4 and 6) and confirm it with button 5 short press.

Full path to this settings menu:
MAIN MENU >> 1. AUTOSTART >> STOP TEMP

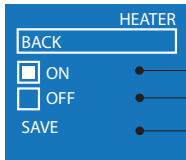

- switching on engine preheater
- switching off engine preheater
- save settings

ENGINE PREHEATER CONTROLS

To configure engine preheater, select HEATER menu using navigation buttons (4 and 6) and confirm it with button 5 short press.

Full path to this settings menu:
MAIN MENU >> 2. HEATER

To start engine preheater, press and hold button 5 for 3 seconds. To switch off engine preheater, press and hold button 5 for 2 seconds.

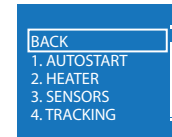

short press

6

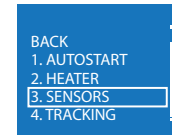

short press

5

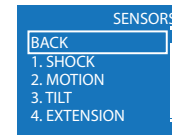

SETTINGS OF THE SENSORS

The system allows setting sensor sensitivity via the remote.

To enter sensor settings menu, select SENSORS option in the main menu using buttons 4 and 6, and confirm it with button 5 short press. Following functions will be displayed:

1. SHOCK – shock sensor settings
2. MOTION – motion sensor settings
3. TILT – tilt sensor settings
4. EXTENSION – supplementary sensor settings

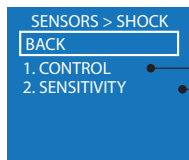

control over shock sensor

adjusting sensitivity of the shock sensor

Shock sensor settings

The system allows full control over built-in shock sensor. To configure shock sensor settings, select SHOCK menu using navigation buttons (4 and 6) and confirm it with button 5 short press.

Full path to this settings menu:
MAIN MENU >> 3. SENSORS >> 1. SHOCK

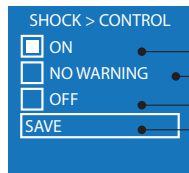

enable shock sensor

disable warning level of the shock sensor

disable shock sensor

save settings

Shock sensor settings. Operation mode controls

To disable warning zone or disable shock sensor completely, select CONTROL option in SHOCK menu using navigation buttons (4 and 6) and confirm it with button 5 short press.

Full path to this settings menu:
MAIN MENU >> 3. SENSORS >> 1. SHOCK >> 1. CONTROL

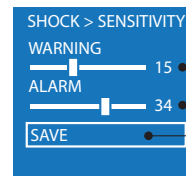

adjustment bar for warning level of the shock sensor

adjustment bar for alarm level of the shock sensor

save settings

Sensitivity settings

To adjust shock sensor sensitivity, select SENSITIVITY option in SHOCK menu using navigation buttons (4 and 6) and confirm it with button 5 short press.

To enter and exit adjustment bar, use button 5, adjust parameters on the bars using buttons 4 (lower sensitivity) and 6 (raise sensitivity). Sensitivity can be adjusted between 0 (lowest sensitivity) and 50 (highest sensitivity).

Full path to this settings menu:
MAIN MENU >> 3. SENSORS >> 1. SHOCK >> 2. SENSITIVITY

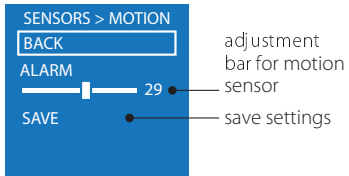

◀ Motion sensor settings

To adjust built-in motion sensor sensitivity, select MOTION option in SENSORS menu using navigation buttons (4 and 6) and confirm it with button 5 short press.

Use button 5 to enter and exit adjustment bar, adjust parameters on the bars using buttons 4 (lower sensitivity) and 6 (raise sensitivity). Sensitivity can be adjusted between 0 (disable motion sensor) and 50 (highest sensitivity).

Full path to this settings menu:
MAIN MENU >> 3. SENSORS >> 2. MOTION

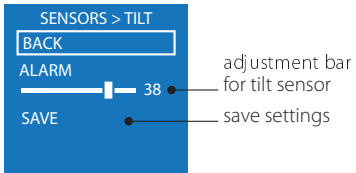

◀ Tilt sensor settings

To adjust built-in tilt sensor sensitivity, select TILT option in SENSORS menu using navigation buttons (4 and 6) and confirm it with button 5 short press.

Use button 5 to enter and exit adjustment bar, adjust parameters on the bars using buttons 4 (lower sensitivity) and 6 (raise sensitivity). Sensitivity can be adjusted between 0 (disable tilt sensor) and 50 (highest sensitivity).

Full path to this settings menu:
MAIN MENU >> 3. SENSORS >> 3. TILT

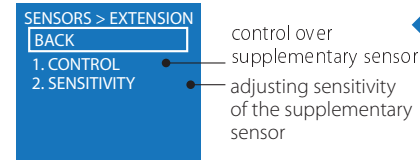

◀ Supplementary sensor settings

The system allows full control over supplementary sensor. To configure shock sensor settings, select EXTENSION menu using navigation buttons (4 and 6) and confirm it with button 5 short press.

Full path to this settings menu:
MAIN MENU >> 3. SENSORS >> 4. EXTENSION

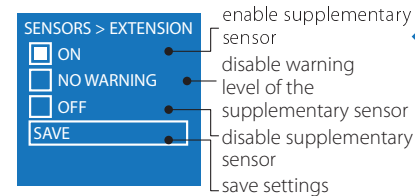

◀ Supplementary sensor settings. Operation mode controls

To disable warning zone or disable supplementary sensor completely, select CONTROL option in EXTENSION menu using navigation buttons (4 and 6) and confirm it with button 5 short press.

Full path to this settings menu:
MAIN MENU >> 3. SENSORS >> 4. EXTENSION >> 1. CONTROL

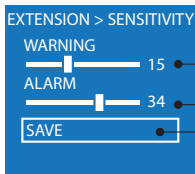

adjustment bar for warning level of the supplementary sensor
 adjustment bar for alarm level of the supplementary sensor
 save settings

Supplementary sensor settings. Sensitivity settings

To adjust supplementary sensor sensitivity, select SENSITIVITY option in EXTENSION menu using navigation buttons (4 and 6) and confirm it with button 5 short press.

To enter and exit adjustment bar use button 5, adjust parameters on the bars using buttons 4 (lower sensitivity) and 6 (raise sensitivity). Sensitivity can be adjusted between 0 (lowest sensitivity) and 50 (highest sensitivity).

Full path to this settings menu:
 MAIN MENU >> 3. SENSORS >>
 4. EXTENSION >> 2. SENSITIVITY



WARNING! Adjusting supplementary sensor sensitivity is available when using Pandora VS volume sensors.

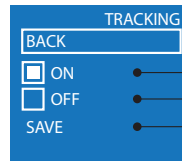

enable tracking
 disable tracking
 save settings

TRACKING OPTIONS

To control tracking function, select TRACKING menu using navigation buttons (4 and 6) and confirm with button 5 short press.

Full path to this settings menu:
 MAIN MENU >> 4. TRACKING

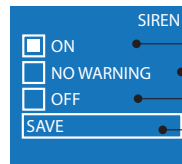

enable all siren signals
 disable warning and service siren signals
 disable all siren signals
 save settings

SIREN SIGNAL OPTIONS

To configure siren signals, select SIREN menu using navigation buttons (4 and 6) and confirm it with button 5 short press.

Full path to this settings menu:
 MAIN MENU >> 5. SIREN

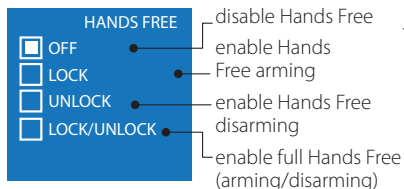

◀ HANDS FREE MODE SETTINGS

The system allows for Hands Free arming and disarming. When the owner with 2,4 GHz radio tag is in range, the system will disarm, and arm again when the owner moves further away from the car.

To select one of Hands Free mods, select HANDS FREE menu using navigation buttons (4 and 6) and confirm it with button 5 short press.

Full path to this settings menu:
MAIN MENU >> 6. HANDS FREE

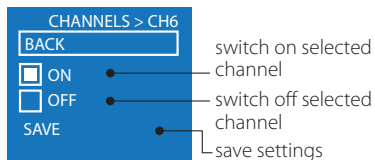

◀ SETTING OF THE TIMER CHANNELS*

The system allows switching on timer channels via remote. Timer channels should be programmed separately using timer channel table in **Pandora AlarmStudio** special software.

To remotely switch on one of the timer channels, select corresponding line (channel number) in CHANNELS list menu using navigation buttons (4 and 6) and confirm it with button 5 short press.

Full path to this settings menu:
MAIN MENU >> 7. CHANNELS >> CH1-CH10

* See Glossary of terms (p. 83).

AlarmStudio can be downloaded from the official company website: pandorainfo.com

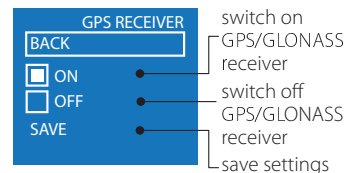

◀ SWITCHING ON/OFF GPS/GLONASS RECEIVER

To control GPS/GLONASS receiver, select GPS RECEIVER menu using navigation buttons (4 and 6) and confirm it with button 5 short press.

Full path to this settings menu:
MAIN MENU >> 8. GPS RECEIVER

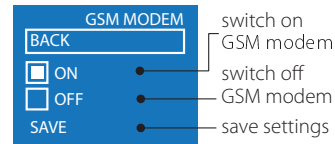

◀ SWITCHING ON/OFF GSM MODEM

To control GSM modem, select GSM MODEM menu using navigation buttons (4 and 6) and confirm it with button 5 short press.

Full path to this settings menu:
MAIN MENU >> 9. GSM MODEM

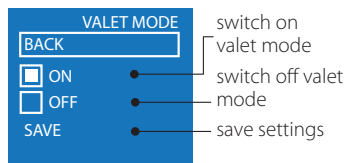

◀ MAINTENANCE/VALET MODE

It is recommended to put system into maintenance/valet mode before handing it to the car service or valet parking. When this mode is switched on, security system stops interfering with built-in electronics and disables all functions to ease maintenance or parking. Moreover, you will not have to leave the remote to the valet or the mechanic.

Disabling valet mode is not possible without using the remote. This feature is implemented to prevent recording additional remotes during maintenance without the owner knowing.

To enable maintenance/valet mode when the engine is stopped and immobilizer tag is within range, select VALET MODE menu using navigation buttons (4 and 6) and confirm it with button 5 short press.

The system will confirm enabled valet mode with green flash of LED indicator when the engine is stopped. Valet mode can only be disabled when the engine is stopped.

Full path to this settings menu:
MAIN MENU >> 10. VALET MODE.

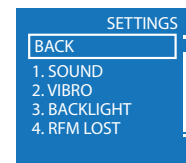

◀ SETTINGS OF THE REMOTE

To enter remote settings, select SETTINGS menu using navigation buttons (4 and 6) and confirm it with button 5 short press. Available functions will be displayed:

1. SOUND – sound signal settings
2. VIBRO – vibration settings
3. BACKLIGHT – LCD backlight brightness settings
4. RFM LOST – radio channel control settings
5. P-ON NOTIFY – online service pro.p-on.ru notification settings
6. LANGUAGE – change remote language (Russian/English)
7. WIDGETS – widgets settings

Full path to this settings menu:
MAIN MENU >> 11. SETTINGS

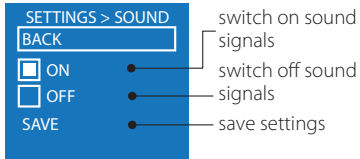

◀ Sound signal settings of the remote

To enter remote sound signal settings, select SOUND option in the SETTINGS menu using navigation buttons (4 and 6) and confirm it with button 5 short press.

Full path to this settings menu:
MAIN MENU >> 11. SETTINGS >> 1. SOUND

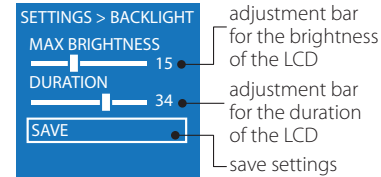

◀ LCD backlight brightness settings of the remote

To enter remote LCD backlight brightness settings, select BACKLIGHT option in the SETTINGS menu using navigation buttons (4 and 6) and confirm it with button 5 short press.

To enter and exit adjustment bar, use button 5, adjust parameters on the bars using buttons 4 (lower brightness) and 6 (raise brightness). Brightness can be adjusted between 0 (disable backlight) and 50 (highest brightness).

Full path to this settings menu:
MAIN MENU >> 11. SETTINGS >>
3. BACKLIGHT

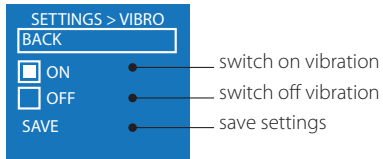

◀ Vibration settings of the remote

To enter remote vibration settings, select VIBRO option in the SETTINGS menu using navigation buttons (4 and 6) and confirm it with button 5 short press.

Full path to this settings menu:
MAIN MENU >> 11. SETTINGS >> 2. VIBRO

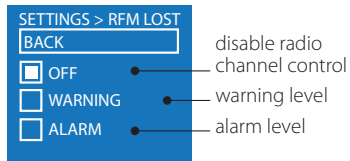

◀ Radio channel control settings

To enter remote radio channel settings, select RFM LOST option in the SETTINGS menu using navigation buttons (4 and 6) and confirm it with button 5 short press.

Full path to this settings menu:
MAIN MENU >> 11. SETTINGS >>
4. RFM LOST

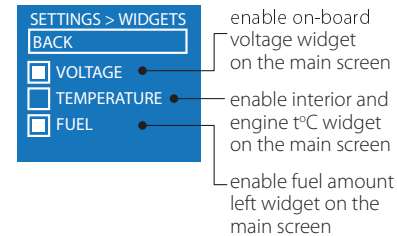

◀ Widgets settings

To enter remote radio channel settings, select WIDGETS option in the SETTINGS menu using navigation buttons (4 and 6) and confirm it with button 5 short press.

Full path to this settings menu:
MAIN MENU >> 11. SETTINGS >>
7. WIDGETS

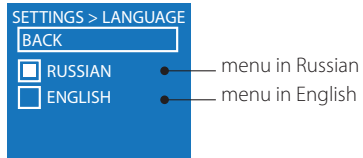

◀ Change remote language

To enter remote radio channel settings, select LANGUAGE option in the SETTINGS menu using navigation buttons (4 and 6) and confirm it with button 5 short press.

Full path to this settings menu:
MAIN MENU >> 11. SETTINGS >>
6. LANGUAGE

CHECKING THE NUMBER OF RECORDED REMOTES

Number of recorded remotes and radio tags can be checked every time the ignition is switched on when disarmed. Number of orange and green LED flashes will indicate number of remotes and tags recorded correspondingly.

Number of recorded remotes and radio tags can also be checked by taking off and putting back on battery terminal. The system will sound a set of signals, corresponding to the number of recorded remotes.

CHARGING THE REMOTE

LCD remote works on accumulator battery that should be charged from time to time via micro-USB cable. Period of operation without recharging depends on conditions and operation rate. On average, one full charge should last 20-30 days.



Micro-USB port for charging and software updates



Immobilizer and owner's personal safety

3

The system has functions that can contribute towards owner's personal safety. The remote has SOS button to call for help in an emergency. In case of car accident, the system will automatically send notifications to owner's close ones. All personal security notifications are supplemented with car current coordinates and web links to online map services. The system uses flexible Antihijack algorithms.

IMMOBILIZER MODE

When ignition is being switched on, the system base unit performs a search for immobilizer tags in radio zone. If no tags were detected, LCD remote will play **'No tag found'** ringtone. If no radio tags were detected when engine start, the system will lock the engine with all radio relays that were programmed into the system. Engine will be blocked only if radio relay motion sensor detects car motion. If additional blocking is installed, doors will be locked immediately, before the car starts moving.

ANTIHIJACK MODE

Antihijack mode helps to prevent aggressive seizure of the car using delayed engine blocking on door opening. Every time when the engine is running on opening/closing a door, immobilizer requests response from the remote using unique algorithm. If the system cannot detect a radio tag, after a door was opened while the engine is running and the car is moving, the engine will be stopped in 60 seconds (general safety requirement). 30 seconds after detecting movement, **'Engine blocking warning'** ringtone will play for the remaining 30 seconds.

If engine blocking is done via radio relay, when warning signals will end, or new attempts to start the engine will commence, immobilizer will only allow it to start when the car is not moving, and will block it again if the car starts moving. Immobilizer will be activated in 2 seconds after the ignition is switched on. If the car starts moving, the immobilizer will block the engine for 15 seconds.

REPLACING IMMOBILIZER TAG BATTERY

When buying a new battery, make sure that its expiration date has not passed and that the battery is not subjected to the corruption.

Triple tone signal will sound every minute when the engine is running if battery charge of the immobilizer tag is low. In this case battery should be replaced soon. Battery type is CR2032.

Carefully open the cover of the tag's battery compartment. Extract discharged battery and insert a new one keeping in mind the correct polarity. Replacing a battery will not cause a loss of tag code information, as authorization data is stored in the non-volatile memory of the MCU.

It is recommended to buy batteries of reliable brands.

Carefully close the cover of the tag's battery compartment. All elements of construction should be rigidly locked in places. If this condition is fulfilled, the tag can operate normally.

IMMOBILIZER CODE USING ORIGINAL CAR CONTROLS

Immobilizer code can consist max of 4 digits from 1 to 9.

Code immobilizer is a function that allows disarming and controlling timer channels using original car controls (button, lever or pedal). To enter immobilizer code, programmed button (lever, pedal) should be pressed a number of times equal the digit of the code. Pauses between presses should not exceed 1 second. Pauses more than 1 second will be interpreted as the start of next digit input.

If immobilizer code was correct, engine blocking or a programmed timer channel will be active (depending on the settings).

PANIC (SOS) BUTTON

In case your life or health are threatened, press **SOS button** and Pandora Professional will automatically perform voice call and send text notification with car coordinates to all programmed emergency numbers.

During emergency voice call, person being called can access car's interior microphone.

EMERGENCY NUMBERS SETTINGS

Emergency phone numbers that will be notified in extreme cases can be programmed in the settings menu of online service pro.p-on.ru in 'Notification settings' section or using Pandora DXL Loader computer software. If you will not program any emergency numbers, voice call and text messages will be received by owner additional numbers.

AUTOMATIC EMERGENCY NOTIFICATIONS

If a car with Pandora Professional telemetric system gets into car accident, automatic notifications will be sent in form of text messages and voice calls.

All emergency events are recorded on a personal page in pro.p-on.ru online service, displaying date, time and coordinates.



Pandora and phone

4

PHONE NOTIFICATIONS

If any of security zones was triggered the system will immediately notify the owner by all available means: it will send alarm notification to the remote, will call and text owner's mobile phone and will save information about the event in **pro.p-on.ru** online service.

SECURITY ZONES TRIGGERED NOTIFICATIONS

- Left/right, front/rear door security zone triggered;
- Trunk security zone triggered;
- Front hood security zone triggered;
- Brake pedal security zone triggered;
- Ignition security zone triggered;
- Warning level of the shock sensor security zone triggered;
- Shock sensor security zone triggered;
- Warning level of the supplementary sensor security zone triggered;
- Supplementary sensor security zone triggered;
- Motion sensor security zone triggered;
- Tilt sensor security zone triggered;
- Voltage outage security zone triggered.

All phone notifications can be set in pro.p-on.ru online service.

RECEIVING VOICE INFORMATION VIA PHONE

Call the system and listen to the status report.

1. System security status: armed/disarmed.
2. If the alarm was triggered, the system will communicate the cause, number of events, time and date (in case events occurred more than 24 hours away).
3. Temperature sensors readings.
4. On-board voltage (to the nearest tenth of a volt).
5. GSM connection signal level.
6. Notification if the remote engine start is programmed, and on what conditions (temperature, time, periodic start).
7. Current time and date.
8. Allows control command input.
9. Voice help in navigating control commands.

CONTROL OVER SYSTEM VIA PHONE

Call the system's phone number. When it answers, enter command code.



WARNING! if the call is not made from the owner's number, guest PIN-code should be entered. Factory set guest PIN-code is 1-2-3-4. After the system is installed, please change factory set PIN-code.

- # • Return to previous menu/state
- * • Repeat the last message
- 1* • Arming
- 0* • Disarming
- 10* • Silent arming
- 00* • Silent disarming
- 11* • Active security mode
- 9* • Help
- 09* • Event history
- 007* • Switch on interior microphone
- 100* • Request GSM account balance
- 123* • Start the engine/prolong heating
- 321* • Stop the engine
- 500* • Request current coordinates

- ①⑤⑥* • Switch on engine preheater
- ⑥⑤①* • Switch off engine preheater
- ④⑤⑥* • Switch on additional channel
- ⑥⑤④* • Switch off additional channel
- ⑦⑧⑨* • Enable automatic engine start
- ⑨⑧⑦* • Disable automatic engine start
- ⑥⑥⑥* • Enable engine blocking
- ⑨⑨⑨* • Disable engine blocking
- ②⑤⑧* • System information
- ⑨⑨⑧* • Disable immobilizer and Antihijack
- ⑧⑧⑧* • Enable immobilizer and Antihijack
- ②②②* • Disable Hands Free mode*
- ②②③* • Enable Hands Free arming*
- ②②④* • Enable Hands Free disarming*
- ②②⑤* • Enable Hands Free disarming only with automatic start*
- ⑦⑤③* • Force connection to the online service

* for systems
3910/3930/3950/3970/
3990/5000 with software
version v.1.75 or higher.

Voice help

The system has voice help menu. During voice call to the system, press # (hash) and listen to the information about system control commands. To end session, hang up the phone.

Repeating the last message

To repeat any message, press * (star) during a voice call to the system.

Arming/disarming

1. Call the system's number and wait for answer.
2. Dial ①* to arm the system or ①* to disarm it.
3. The system will confirm:
'Arming/disarming'.

Enabling active security

1. Arm the system using any method.
2. Call the system's number and wait for answer.
3. Dial ①①*.
4. The system will confirm:
'Active security mode enabled'.

To end session hang up the phone.

You will receive text notification that active security mode is enabled.

Event history

1. Call the system's number and wait for answer.
2. Dial **09***
3. Listen to the information about the latest event that is registered by the system.

To navigate event history, press **4** (listen to the previous/earlier event), or **6** (listen to the next/later event).

Switching on interior microphone

1. Call the system's number and wait for answer.
2. Dial **007***
3. The system will confirm execution and will switch on interior microphone.

Request GSM account balance

1. Call the system's number and wait for answer.
2. Dial **100***
3. The system will confirm: 'Balance information sent via text message' and will send text message with account balance information to your phone.

Request current coordinates

1. Call the system's number and wait for answer.
2. Dial **500***
3. The system will confirm: 'Current coordinates sent via text message' and will send text message with coordinates and a web link to a map to your phone.

Switching on/off additional channel

Pandora system can control additional timer channel:

1. Call the system's number and wait for answer.
2. Dial **456*** to switch on the channel or **654*** to switch off.
3. The system will confirm execution.

Switching on/off engine preheater

Pandora system has additional channel to control engine preheater:

1. Call the system's number and wait for answer.
2. Dial **156*** to switch on the channel or **651*** to switch off.
3. The system will confirm execution.

Enabling/disabling automatic engine start

Pandora system has function of prompt disabling automatic engine start:

1. Call the system's number and wait for answer.
2. Dial **987*** to disable all automatic engine starts or **789*** to enable.
3. The system will confirm execution.

If all automatic engine starts are disabled,  icon will go out on the remote. All automatic engine starts will be blocked. Automatic starts can be enabled again by dialing **789*** (all previous settings will remain intact) or by programming new parameters using the remote.

Blocking/unlocking the engine

You can block car engine using any phone. The engine will remain blocked until phone command 'Unlock engine' will be sent. This blocking cannot be disabled using a remote.

1. Call the system's number and wait for answer.
2. Dial **666*** to enable engine blocking or **999*** to disable it (after dialing you should enter individual PIN-code that is located on the owner's plastic card).

Switching off immobilizer

In case radio tag was lost or broken, the system has switching off function for immobilizer and Antihijack:

1. Call the system's number and wait for answer.
2. Dial **998*** (after dialing you should enter individual PIN-code that is located on the owner's plastic card).
3. The system will confirm execution.

Switching on immobilizer

To restore the functions of immobilizer and Antihijack:

1. Call the system's number and wait for answer.
2. Dial **888***
3. The system will confirm execution.

CHANGING CORE SETTINGS VIA PHONE

System settings can be changed using a phone.

To enter programming mode, call the system's number, wait for answer, then press and hold  button on LCD remote. The system will proceed to settings programming mode.

Program main settings using voice help.

1 *

Phone number settings

1 * • Owner's number -> **#**

2 * • Additional owner's number -> **#**

3 * • Second additional owner's number -> **#**

4 * • Account balance inquiry number -> **#**

2 *

Settings of the voice calls

- 1 * • Voice calls on alarm
- 2 * • Voice calls on triggering warning level of the sensors
- 3 * • Voice calls on engine start
- 4 * • Voice calls on engine stop
- 5 * • Voice calls on restoring GSM connection
- 6 * • Voice calls on disarming
- 7 * • Voice calls on entering programming mode
- 8 * • Voice calls when radio relay connection is lost
- 9 * • Voice calls when on-board voltage is low
- 0 * • Voice calls on accident

3 *

Settings of the text messages

- 1 * • Text messages on alarm
- 2 * • Text messages on triggering warning level of the sensors
- 3 * • Text messages on engine start
- 4 * • Text messages on engine stop
- 5 * • Text messages on restoring GSM connection
- 6 * • Text messages on disarming
- 7 * • Text messages on entering programming mode
- 8 * • Text messages when radio relay connection is lost
- 9 * • Text messages when on-board voltage is low
- 10 * • Text messages on accident

4 *

Immobilizer settings

- 1 * • Immobilizer (on/off)
- 2 * • Antihijack

5 *

Additional settings

- 1 * • Changing guest PIN-code
- 2 * • Entering as guest
- 3 * • Remote blocking
- 4 * • Switch on interior microphone
- 5 * • Set threshold voltage for sending text message

6 *

Automatic engine start settings

- 1 * • By time
- 2 * • Set up time for automatic start
- 3 * • By voltage
- 4 * • Set up voltage for automatic start
- 5 * • By temperature

6 *

- Set up temperature for automatic start

7 *

- By period

8 *

- Set up period for automatic start

7 *

Sensor sensitivity settings

- 1 * • Settings of the warning level of the shock sensor sensitivity
- 2 * • Settings of the alarm level of the shock sensor sensitivity
- 3 * • Settings of the motion sensor sensitivity
- 4 * • Settings of the warning level of the supplementary sensor sensitivity
- 5 * • Settings of the alarm level of the supplementary sensor sensitivity
- 6 * • Settings of the tilt sensor sensitivity

8 *

Settings of saving mode

- ① * • GSM connection
- ② * • Money saving mode of the GSM connection
- ③ * • Voice calls in roaming service

9 *

Current time and date settings

- ① * • Set up date
- ② * • Set up time

Pandora**Pandora online information service pro.p-on.ru and mobile apps**

SYSTEM LOGIN

To access your individual page in pro.p-on.ru information service, use login/password from the owner's plastic card under protective layer. Enter login and password into corresponding text fields on a website or in the mobile app. Login/password are case sensitive.

PIN	LOGIN	PASS
2-2-2-2	50023522	Y34aC4vJ
+X-XXX-XXX-XX-XX		

The system's phone number

EVENT HISTORY

Event history holds more than 100 different types of events, that can happen to the system. Event history in online service starts with system's production and is available to the owner at any time from any device with the Internet connection.

Every event is saved with date, time, coordinates and status of all control zones at the moment the event has occurred.

Event history	
18 of January	
09:00	Arming 165 Fleet St, London EC4A 2DY, UK
08:35	Disarming 218 st Johns street, London EC1V 4AT, UK
08:24	Engine start 218 st Johns street, London EC1V 4AT, UK
17 of January	
18:34	Arming 218 st Johns street, London EC1V 4AT, UK
18:00	Disarming 165 Fleet St, London EC4A 2DY, UK
17:50	Engine start 165 Fleet St, London EC4A 2DY, UK
09:00	Arming 165 Fleet St, London EC4A 2DY, UK

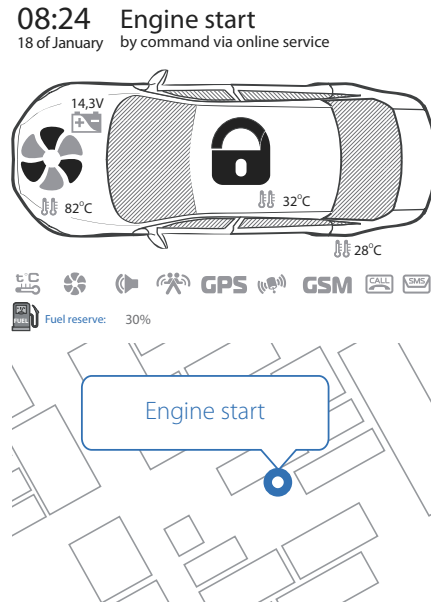

SYSTEM STATUS INFORMATION

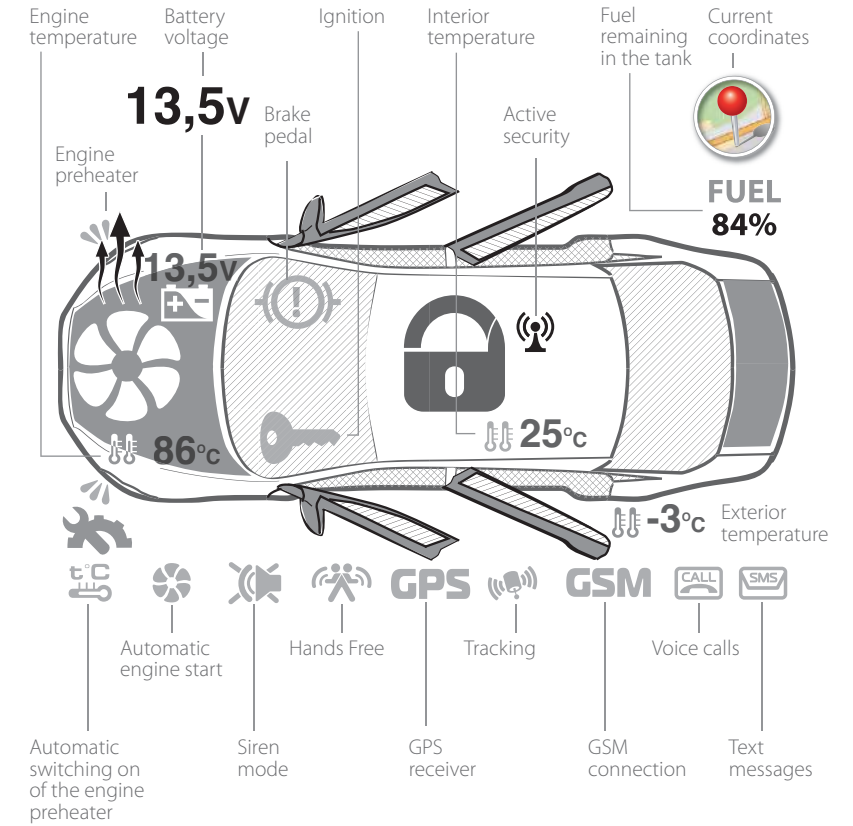

SECURITY AND WARNING ZONES

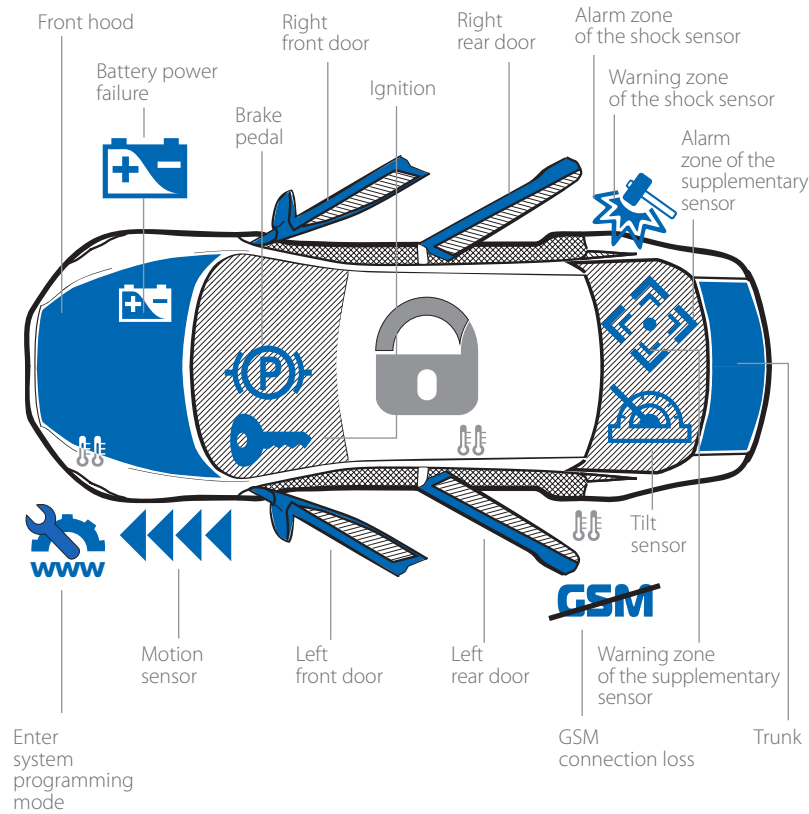

CAR MOVEMENT HISTORY (TRACKING)

Online service stores car movement history (tracking history) for 30 days. Using this function, you can track car movements, analyze traveled distance and time, average speed. Track also shows direction of the movement, speed limits (color coded), speed and exact time in every point of the track, a point with maximum speed per track.

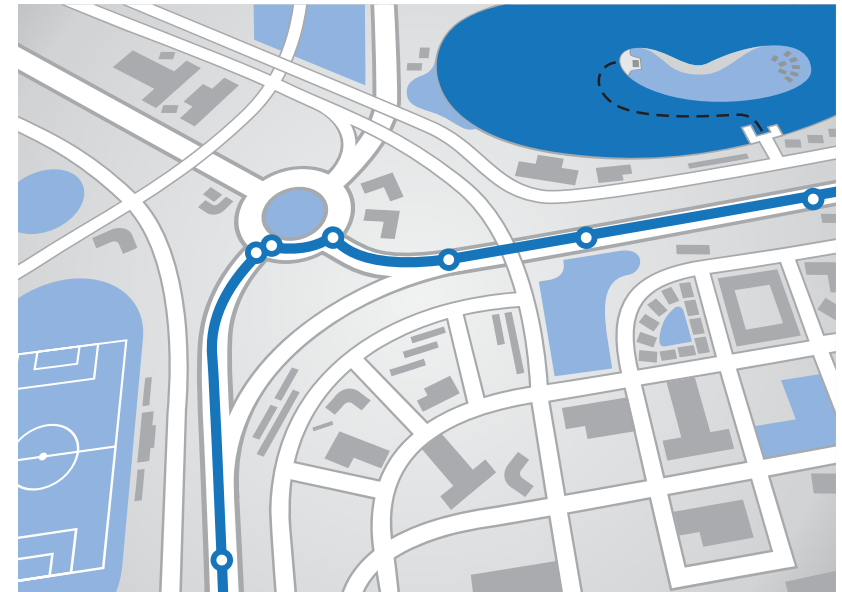

SMARTPHONE APPS

To ease access to the online service, Pandora Pro (for iOS) and Pandora Online (for Android) mobile apps have been developed. These apps are free and available through your device's app store (AppStore, Google Play).



Control in case of emergency

6

CONTROL OVER SYSTEM IN CASE OF EMERGENCY, ENTERING INDIVIDUAL PIN-CODE



WARNING! Make sure that protective layer on the owner's plastic card is intact after the system installation. Plastic card holds individual PIN-code and online service access information.

In case you cannot disarm the system using a remote, phone or online service, owner's individual PIN-code can be used.

Individual PIN-code is written on the owner's plastic card under protective layer. Erase the protective layer and use VALET button to input the PIN-code.

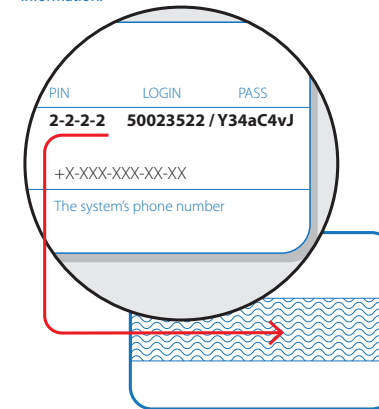

1. Using VALET button, input the first digit of the code (press the button a number of times, equal to the first digit; pauses between presses should not exceed 1 second). The system will confirm with red LED indicator flash.
2. Similarly input second, third and fourth digit. Every input will be confirmed with red LED flash.

3. The system will confirm correct PIN-code with red and green flashes of LED indicator. If the input was incorrect, it will be indicated with long red flash. New input can be attempted in 5 seconds.
4. If the system was armed, it will be disarmed after entering the correct PIN-code.

If the system is disarmed and the engine is stopped, the system will enter programming mode after entering PIN-code.

For emergency arming when the engine is stopped, press and hold VALET button for 3 seconds. The system will confirm with siren sound signal and will be armed in 30 seconds.

While there is a countdown, LED indicator will be lit red.



Any problem can be solved

7

Problem	Solution
When pressing button 1 on the LCD remote all icons are lit, when pressing button 2 the numeric indicator will be lit.	The remote is switched off, it should be switched on. Press and hold button 3 (F) for 3 seconds.
LCD remote has stopped playing ringtones.	Low battery power. Please, charge the battery (page 52).
Cannot disarm the system using a remote.	Use additional remote or disarm using a phone command (0*). Contact the car service that was installing the system.
LCD remote is vibrating constantly.	Low battery power. Please, charge the battery (page 52).
1 minute after the ignition was switched off, 'Signal lost' ringtone plays and LED indicator starts flashing red.	The system reminds you that it is disarmed. Please, arm the system.

Important information

Problem	Solution
The alarm constantly goes off by the sensor data.	The sensitivity is too high. Reduce sensor sensitivity (page 37).
System does not send text notifications.	1. Text message service center number is incorrect. The system determines it automatically. However, it should be changed if changing mobile operator of the system. Contact the car service that was installing the system. 2. Text messaging is blocked by the mobile operator. Contact your system's mobile operator.
The system cannot be reached when calling from supplementary owner's number.	When calling the system from any number, different from the main owner's number, guest PIN-code should be entered. Factory preset guest PIN is 1-2-3-4. It can be changed in the settings.
The system cannot determine owner's number.	Some mobile providers use different country code prefixes (e.g. +44 or 0 for UK). Please, use the correct prefixes that your mobile operator uses when programming the system.
The system cannot reach owner's supplementary number when alarm is triggered.	Owner's main number has voice mail turned on. Disable it for the system not to get stuck.
Cannot login to the individual page in prop-on.ru online service.	Please, note that login and password are case sensitive. If you have changed the password, you can reset it to the factory value (written on the plastic card) using a link on the login web page.

SIREN SOUNDS AND TURN LIGHT SIGNALS

Signal name	Signal description
Alarm mode	Incessant sound and light signals for 30 seconds
PANIC mode	Incessant sound and light signals for 30 seconds
Arming	1 sound and 1 light signals
Disarming	2 sound and 2 light signals
'Sensors triggered' signal when disarming	4 sound and 4 light signals
'Sensor malfunction' signal when arming	4 sound and 4 light signals
Sensor warning level triggered	3 sound and 1 light signals
Disabling warning level of the shock sensor	1 sound and 1 light signals
Car search	5 sound and 5 light signals

MEANING OF INDICATOR LED COLORS

Indicator status	Meaning
Short red flashes	The system is armed
Lit red	The system is preparing for automatic arming, immobilizer mode on
Orange flash	Confirms VALET button presses
Orange flashes	Confirms a number of recorded remotes (when switching on ignition)
Green flashes	Antihijack mode enabled
Lit green	Maintenance (valet) mode ON (when ignition is switched on)
Red and green flashes	PIN-code confirmed, immobilizer mode disabled
Faded	The system is disarmed

GLOSSARY OF TERMS

AlarmStudio – an installation helper software that is to be installed on a Windows PC (preferably, laptop). AlarmStudio allows changing any parameters in the system and provides installation tips for particular cars. Easy to use and intuitive, AlarmStudio is required for in-depth and highly customized installation. Installation without AlarmStudio, although entirely possible, may be incomplete and lacking in functionality.

Base Unit – it is a small box that acts as a 'brain' of the system. It contains a printed circuit board, sensors and supplementary devices like 3D accelerometer and sockets for connecting it to car systems. Powerful processor unit and ingenious algorithms allow for hundreds of programmable parameters, accessible via AlarmStudio (and via VALET button for some).

Car alarm system – a set of third-party electronic devices that are installed in a car body and connected to its electric and data networks in order to provide enhanced security.

Car service-security system – same as car alarm system but with more service options, e.g. telemetry, remote engine start, various control options.

Channel – a name we use in our service-security systems to indicate a combined position and function of particular output socket and corresponding wiring.

Original security system – a built-in security system that is present on some car models. You can set up particular logic of interaction between this system and ours – control over it.

Telemetry – in car service-security systems is a combined capability to gather, process and convey to user various data regarding the car – temperatures, voltages, fuel level, sensor data, etc.

Timer channel – a term we use in our service-security systems to name channels that activate additional options or accessories (e.g. seat heating, light path, additional block relays). Any channel (output) can be set as timer channel, that can be activated from the remote, or incorporated into scheduled and sequential routines. To assign timer channels, use AlarmStudio.

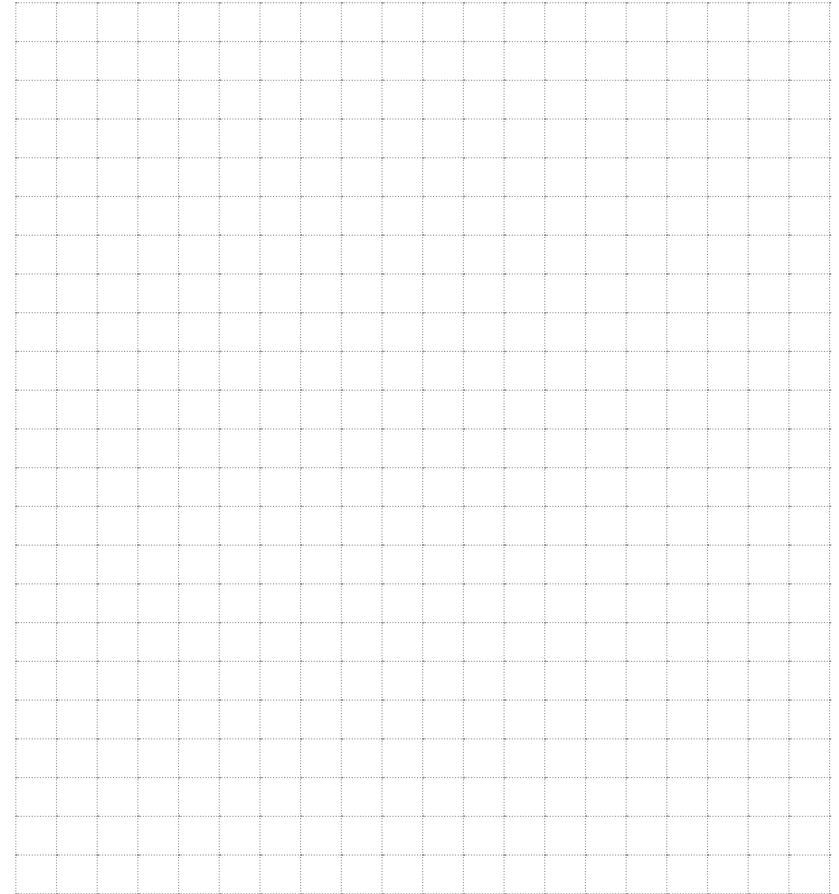

SYSTEM MODULES LAYOUT

Ask the installer to mark system modules on the provided picture. This information can be important for diagnostics in case of system malfunctions.

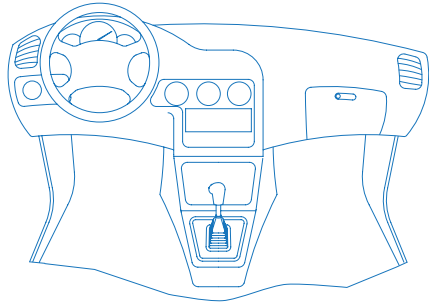

- ① Base unit
- ② RF module
- ③ VALET button
- ④ Blocking radio relay
- ⑤ GSM aerial
- ⑥ Automatic start module
- ⑦ GPS receiver

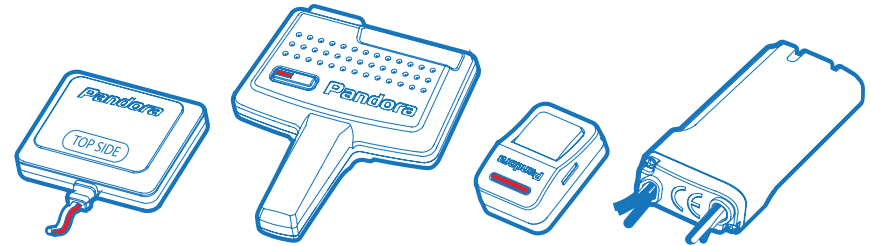
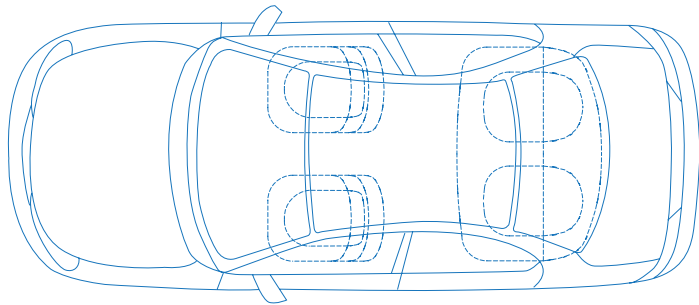

GPS/GLONASS receiver NAV-03

RF-module

LED indicator and VALET button

Blocking radio relay

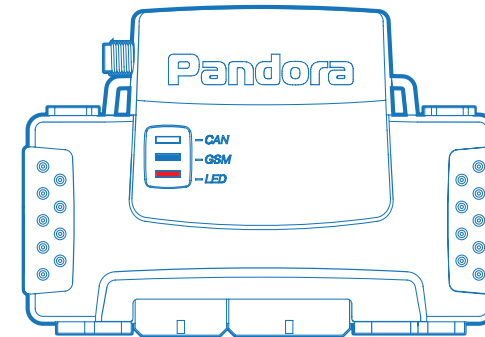

Base unit

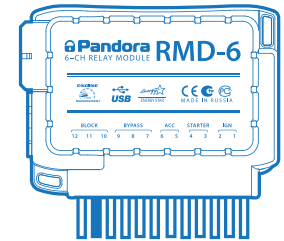

Automatic start module



GSM aerial



Temperature sensor



Microphone

WARRANTY OBLIGATIONS

Manufacturer guarantees correct operation of the service-security system if exploitation, installation, storage and transportation conditions described in this manual were met.

The system should only be used according to installation scheme and user manuals.

The system is meant to be installed by the professional car electronics installers. We recognize that outside Russia the system can be installed by amateurs – those installations are still a subject of limited warranty. The installer should fill in installation certificate that is included in this manual.

Parts malfunctioning during warranty period on the fault of the manufacturer should be repaired or replaced by the installation center of the manufacturer or by certified service center. List of certified service centers outside Russia can be found on pandorainfo.com

The user loses the right for warranty services in the following cases:

- when warranty period expires;
- if exploitation, installation, storage or transportation conditions were not met;
- if there is mechanical damage of the external parts of the system after it is sold. This includes: fire damage, consequential damage in case of car accident, aggressive liquids and water seeping damage, damage caused by improper use;
- if the damage was caused with incorrect settings and parameter adjustment;
- if system devices are replaced with any devices that are not recommended by the manufacturer;
- if manufacturer sealing is broken;
- if there is no properly filled warranty card and installation certificate.

Warranty period is 3 years since the moment of purchase, but no more than 3,5 (three and a half) years since the moment of production.

This warranty does not include batteries of the remotes, as they have their own service life time.

Maintenances and repairs of the system with expired warranty period are carried out at the expense of the user on a separate contract between the user and the installer/service center.

Transportation rules

Products should be transported in the original packaging by any means of transport as long as they are protected from mechanical damage and precipitation.

Packaged products should be stored on racks in piles of 6 or less boxes, in enclosed, dry, heated rooms (no less than 1m from heating) which exclude possible interaction with moisture, oil products and damaging environmental factors.

INSTALLATION CERTIFICATE

I, the undersigned _____
Position, name

professional installer, certify that installation of the service-security system, specified below, was carried out by me in accordance with manuals and schemes provided by the manufacturer.

Car specifications:

Car model _____

Type _____

ID number (VIN) _____

Registration number _____

Security system specifications:

Model **Pandora Professional**

Serial number _____

Service center name, full address and installer's stamp _____

Signature _____ / _____ /
Signator

Work accepted _____ / _____ /

Date ' ____ ' _____ 20 ____ y
Signator

ACCEPTANCE CERTIFICATE

Pandora Professional is in conformity with Electromagnetic Compatibility Directive EMC 2004/108/EC and R&TTE Directive 1999/5/EC.

Serial number _____

Date of production _____

Responsible person's signature _____

(stamp)

Packager _____

Signature (personal stamp)

WARRANTY CARD

Model **Pandora Professional**

Serial number _____

Date of purchase ' ____ ' _____ 20 ____ y

Seller's (installer's) stamp

Seller's signature

