

**WARNING!** Before starting the installation of the system, choose a car model in the ALARM STUDIO (CAN-bus protocol).  
**WARNING!** Do not shield the built-in antennas.  
**WARNING!** All power circuits of additional devices that are not powered through the base unit of the system should have their own fuses.  
**WARNING!** The security system does not require regular maintenance. In case of malfunction it should be taken to a specialized service center.

**IT IS FORBIDDEN** to install the system on a car with normal voltage other than 12V.  
**IT IS FORBIDDEN** to bypass original fuses of a security system in the installation process.  
**IT IS FORBIDDEN** to install the security system with damaged output cables.

**WARNING!** All additional devices included in the system set are paired with the system.  
**WARNING!** The maximum number of paired Bluetooth devices must not exceed 14.  
**WARNING!** Pairing of additional devices must be carried near the base unit (the distance must be no more than 2 meters).

X7 connector (IMMO-KEY) can be used for remote engine start (see installation manuals on loader.pandorainfo.com or in the AlarmStudio).  
 If you use the IMMO-KEY port to implement remote engine start, disable all settings of the inputs INP1 and INP7 (INP1 has factory logic – "Trunk" input).

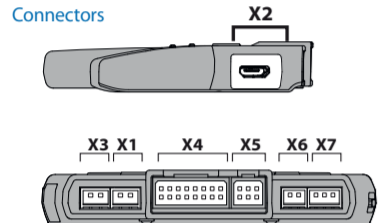
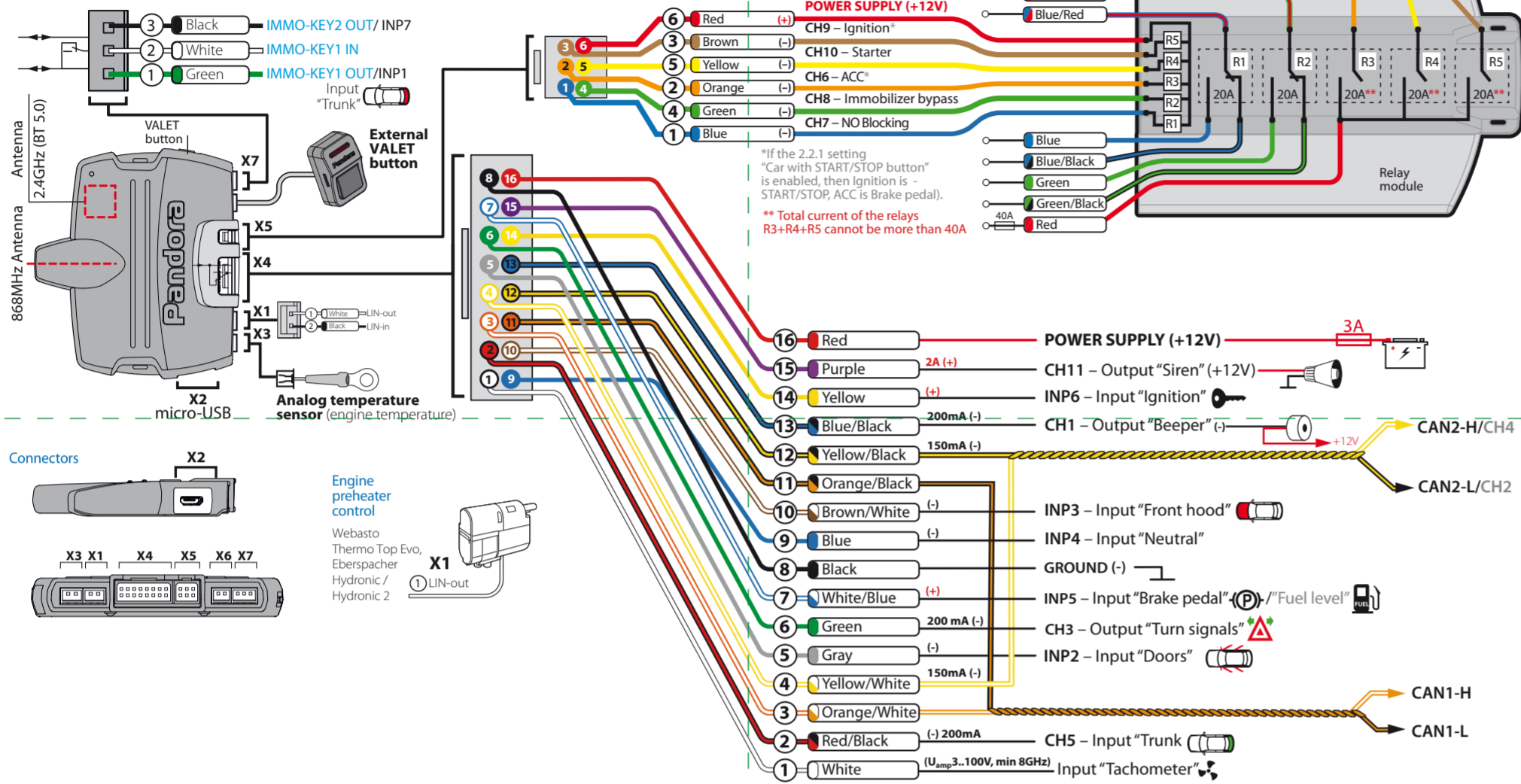

#### №1 An example of pairing remote controls D022/D030

Enter the programming level №1 – "Pairing remote controls". The LED will light green or red. The red LED means a D030 remote control has been already paired, press and hold the VALET button for 3 seconds to delete it.  
 • Press and hold 3 buttons of a remote control (arm/disarm/F) simultaneously for 1 second (until a short beep), then release the buttons.  
 • If pairing was successful, a siren/beeper of the base unit will sound a beep.

After this you can pair the next remote control or finish the procedure. To finish pairing, press the VALET button once (series of red and green flashes of the LED indicator and series of sound signals of the Beeper will confirm saving). The system will enter the programming level №0.

#### №10.1 An example of pairing radio tags BT760

Enter the programming level №10.1.1...3 – "Pairing radio tags". The LED will light green or red (the red LED means a radio tag has been already paired).  
 • Press the control button on a tag and hold it for 6 seconds (6 flashes of the tag status indicator), release the button after the sixth flash.  
 • If pairing was successful, the LED will light red and a siren/beeper of the base unit will sound a beep.

system will automatically enter the programming level №0 (series of red and green flashes of the LED indicator and series of sound signals of the Beeper will confirm that).

#### №10.3 An example of pairing door sensor DMS-100 BT

Enter the programming level №10.3.1...4 – "Pairing door sensors". The LED will light green or red (the red LED means a door sensor has been already paired).  
 • Open the plastic case 1 of the sensor carefully and insert a battery 2 into the sensor.  
 • If pairing was successful, the LED will light red and a siren/beeper of the base unit will sound a beep. The system will automatically enter the programming level №0 (series of red and green flashes of the LED indicator and series of sound signals of the Beeper will confirm that).  
 • Exit the programming mode.

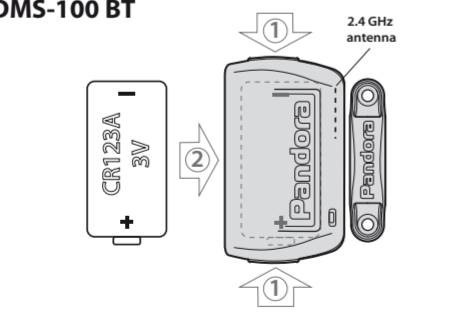

#### №10.4 An example of pairing radio relays BTR-101

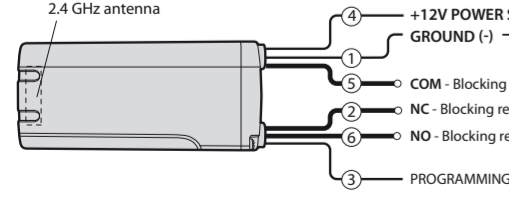

Enter the programming level №10.4.1 or №10.4.2 – "Pairing radio relays". The LED will light green or red (the red LED means a radio relay has been already paired).  
 • Connect the wire 1 (GROUND) to a grounded spot of a car.  
 • Connect the wire 3 (PROGRAMMING) to wire 4 (+12V POWER SUPPLY). Connect them to +12V.

If pairing was successful, the LED will light red and a siren/beeper of the base unit will sound a beep. The system will automatically enter the programming level №0 (series of red and green flashes of the LED indicator and series of sound signals of the Beeper will confirm that).  
 • Exit the programming mode.  
 • Disconnect the wire 3 (PROGRAMMING) from the wire 4 and insulate all unused wires.

#### №10.7 An example of pairing a radio relay BT-01

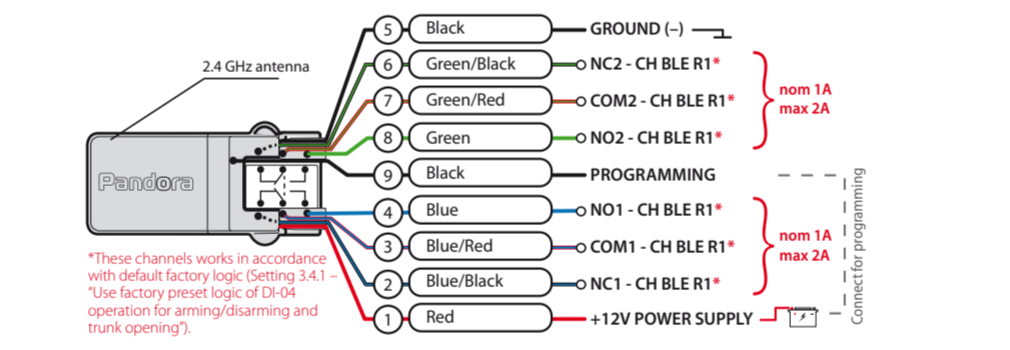

Enter the programming level №10.7 – "Pairing an additional device". The LED will light green or red (the red LED means a radio relay has been already paired).  
 • Connect the wire 5 (GROUND) to a grounded spot of a car (-).  
 • Connect the wire 9 (PROGRAMMING) to wire 1 (+12V POWER SUPPLY). Connect them to +12V.  
 • If pairing was successful, the LED will light red and a siren/beeper of the base unit will sound a beep. The system will automatically enter the programming level №0 (series of red and green flashes of the LED indicator and series of sound signals of the Beeper will confirm that).  
 • Disconnect the wire 9 (PROGRAMMING) from the wire 1 and insulate all unused wires.  
 • Set operation logic of the R1 relay.  
 • Exit the programming mode.

#### №10.7 An example of pairing a radio module DI-04 BT

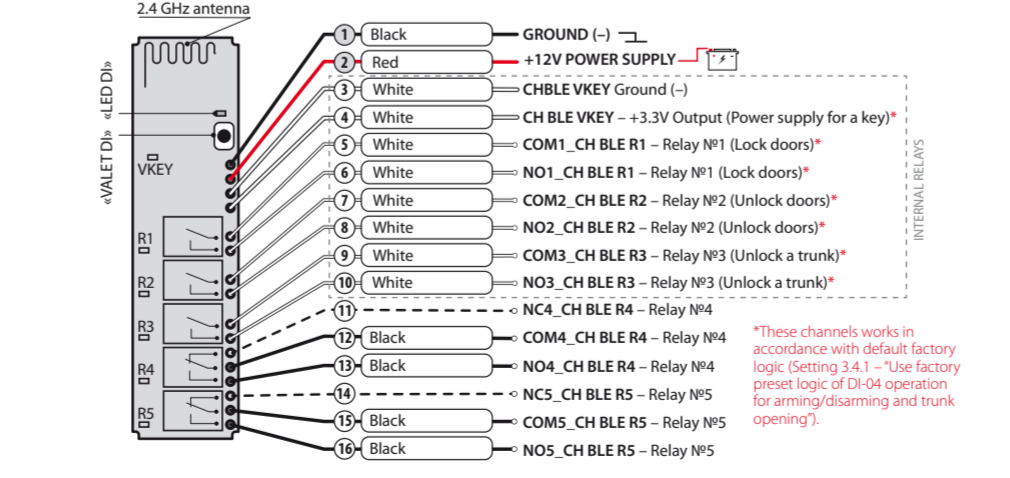

Enter the programming level №10.7 – "Pairing an additional device". The LED will light green or red (the red LED means a device has been already paired).  
 • Connect the module power supply.  
 • Press and hold the "VALET DI" button for 6 seconds (6 flashes of the "LED DI". Release the button after the sixth flash).  
 • If pairing was successful, the LED will light red and a siren/beeper of the base unit will sound a beep. The system will automatically enter the programming level №0 (series of red and green flashes of the LED indicator and series of sound signals of the Beeper will confirm that).  
 • Set operation logic of the R1...R5, VKEY relays.  
 • Exit the programming mode.

Function	VALET button		
	Level	Delete	Update
№0 – Entering a level			
№1 – Pairing remote controls D022 – up to 4 remotes/ D030 – 1 remote*	P1	H3*	
№2 – Changing the Service PIN-code	P2		
№3 – Recording the idle speed (rpm)	P3		
№4 – Reset to the factory settings	P4	H4*	
№10.1.1 – Pairing a radio tag BT760	H1→P1→P1	H3	
№10.1.2 – Pairing a radio tag BT760	H1→P1→P2	H3	
№10.1.3 – Pairing a radio tag BT760	H1→P1→P3	H3	
№10.3.1 – Pairing a door sensor DMS-100 BT	H1→P3→P1	H3	H5
№10.3.2 – Pairing a door sensor DMS-100 BT	H1→P3→P2	H3	H5
№10.3.3 – Pairing a door sensor DMS-100 BT	H1→P3→P3	H3	H5
№10.3.4 – Pairing a door sensor DMS-100 BT	H1→P3→P4	H3	H5
№10.4.1 – Pairing a radio relay BTR-101	H1→P4→P1	H3	H5
№10.4.2 – Pairing a radio relay BTR-101	H1→P4→P2	H3	H5
№10.5 – Pairing a mobile phone	H1→P5	H4	
№10.6 – Pairing an engine compartment module RHM-03BT	H1→P6	H3	H5
№10.7 – Pairing an additional device DI-04 or BT-01	H1→P7	H3	H5
№10.8 – Pairing a telemetry module Pandora Eye Pro	H1→P8	H3	H5
№10.9 – Pairing a GPS-receiver NAV-035 BT	H1→P9	H3	H5
№10.10 – Updating Bluetooth modem firmware	H1→P10		
№11 – Programming and configuring an "Immobilizer PIN-code"	H1•P1		
№12 – Fuel level calibration	H1•P2		
№13 – Emergency deactivating/activating code immobilizer function (pin-to-drive)	H1•P3		
№15 – Emergency deactivating/activating authorization devices (immobilizer, anti-hijack)	H1•P5		
№17 – Programming bypass of an original immobilizer	H1•P7		
№50 – Pairing a mobile phone	H5		
№100 – Exit the programming menu	H10		

P – press X times H – hold for X sec. → – sec. pause • – without a pause  
 \* only for D-030 remote control

#### №10.6 An example of pairing a radio module RHM-03 BT

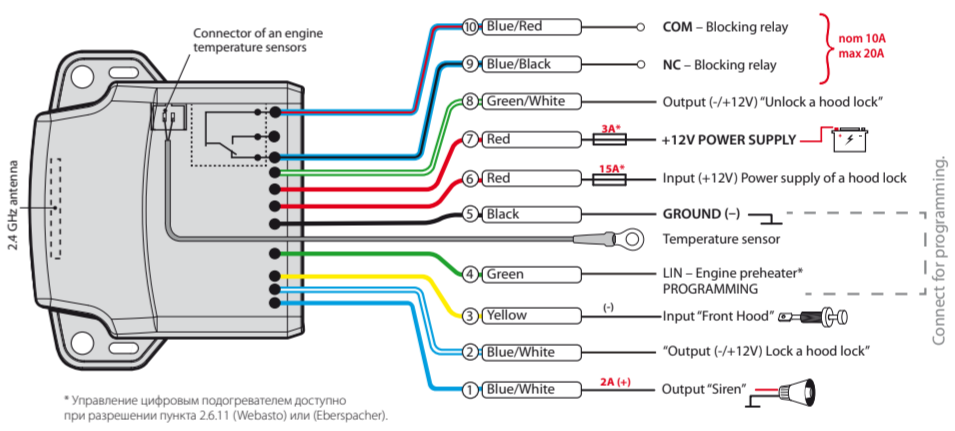

Enter the programming level №10.6 – "Pairing an engine compartment module". The LED will light green or red (the red LED means a module has been already paired).  
 • Connect the wire 4 (PROGRAMMING) to wire 5 (GROUND). Connect them to ground (-).  
 • Connect the wire 7 (+12V POWER SUPPLY) to +12V.  
 • If pairing was successful, the LED will light red and a siren/beeper of the base unit will sound a beep. The system will automatically enter the programming level №0 (series of red and green flashes of the LED indicator and series of sound signals of the Beeper will confirm that).  
 • Exit the programming mode.  
 • Disconnect the wire 4 (PROGRAMMING) from the wire 5 and insulate all unused wires.

#### №10.8 An example of pairing a telemetry module Pandora Eye Pro

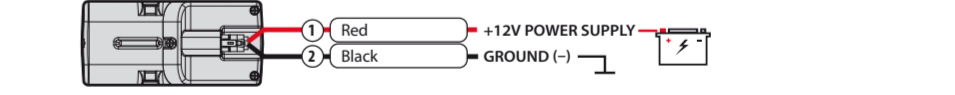

Enter the programming level №10.8 – "Pairing an telemetry module". The LED will light green or red (the red LED means a module has been already paired).  
 • Connect the module power supply.  
 • Enter the programming level №1 of the Eye Pro module – "Pairing the module with a security-service system".  
 • If pairing was successful, the LED will light red and a siren/beeper of the base unit will sound a beep. The system will automatically enter the programming level №0 (series of red and green flashes of the LED indicator and series of sound signals of the Beeper will confirm that).  
 • Press the VALET button of the Eye Pro module to finish pairing.  
 • Exit the programming mode.

#### №10.9 An example of pairing a GPS/GLONASS-receiver NAV-035BT

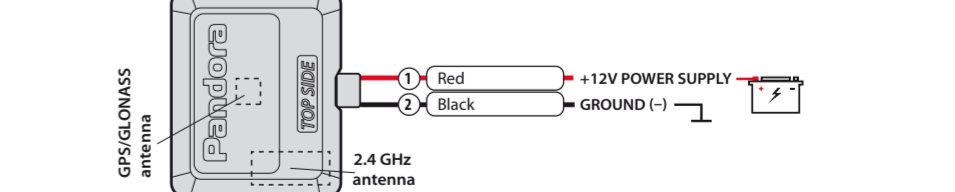

Enter the programming level №10.9 – "recording a GPS/GLONASS-receiver". The LED will light green or red (the red LED means a module has been already paired).  
 • Connect the receiver power supply.  
 • If pairing was successful, the LED will light red and a siren/beeper of the base unit will sound a beep. The system will automatically enter the programming level №0 (series of red and green flashes of the LED indicator and series of sound signals of the Beeper will confirm that).  
 • Exit the programming mode.

## PROGRAMMING THE SYSTEM

System settings and parameters can be configured using the Pandora Alarm Studio application. Some functions can be configured only by the programming menu of the system. It is required to put the system to programming mode to get access to the settings.

### Entering/Exiting programming mode

You can enter the programming mode only if the base unit is powered form a USB cable or the main power supply is connected, the ignition is off, the system is disarmed and service mode is off. To enter programming mode, enter the "Service PIN-code" (default value is 1-1-1-1) using an external VALET button or the VALET button located on the base unit.

**NOTE!** See the detailed description of PIN-code entering procedure in the "CONTROL OVER THE SYSTEM IN CASE OF EMERGENCY" section of the user manual.

If you don't have the 'Service PIN-code', you can enter programming mode using the 'Secret PIN-code' written on the owner's card.

The system stops to execute commands when it is in programming mode. Therefore, exit programming mode after changing settings and parameters of the system. To exit programming mode, use one of the following methods:

- Press and hold the VALET button for more than 10 seconds;
- Turn on and then turn off the ignition when a

### Level №4 – Reset to the factory settings

**NOTE!** The procedure recovers the factory settings of the system without deleting previously registered devices (tags, mobile device, relays, etc.) that is stored in the non-volatile memory.

Enter the programming level №4.

- Press and hold the VALET button for more than 4 seconds. Release the button after a sound of the Siren/Beeper. The system will confirm the resetting to the factory settings with a long red flash of the LED indicator. After that, the system will reset the settings to default and return to the programming level №0.

### Level №10 – Control Bluetooth devices Updating Bluetooth modem firmware

**ATTENTION! All functions of this level are available in the Pandora BT.**

This level is used to pair/remove/update additional devices and to update Bluetooth modem of the system. Each device is paired at a sublevel. To pair devices of the same type, a sublevel is divided into cells. To enter a sublevel or a cell of sublevel make a pause for more than 1 second (➔), then press **(P)** the VALET button the number of times equals to the desired sublevel or cell number: "Level №10 ➔ (1sec) "Sublevel 1...**10**" ➔ (1sec) "Cell of sublevel 1...4".

#### • Pairing/Deleting an additional device

Each sublevel or cell displays its current state by a color of the LED: green light means the system is ready for pairing, red light means a device has

system will return to the programming menu. Enter the 'Secret PIN-code' that is written on the owner's card. The system will confirm deactivating the function with a long red LED flash, two sound signals of the siren and sound signals of the beeper.

#### • Activating the function

The LED indicator will light red and the beeper will emit a long sound signal after entering the programming level. The system will wait for an action. Press the VALET button once to activate the function. The system will confirm activating with a green LED flash and one short sound signal of the siren and beeper.

### Level №17 – Programming bypass of an original immobilizer

Bypass learning procedure is performed on this level.

**NOTE!** See the detailed instruction in the installation manuals for cars.

### Level №50 – Pairing a mobile phone

**NOTE!** See the detailed description in the "MOBILE APPLICATIONS" section of the user manual.

The system supports only one mobile device. If a mobile device has been already paired, it will be deleted when you enter this level. When you overwrite the same device in the system memory, you should delete the Bluetooth connection on your mobile device, delete the

USB cable is disconnected and the main power supply of the system is connected;

- Disconnect the power supply (main and USB power supply).

The system will reboot programmatically (all changes will be saved) after exiting programming mode. All ways to exit programming mode are accompanied by sound signals of the siren and light signals of the LED indicator. The light signals indicate the number of paired control devices.

**NOTE!** See the "Checking the number of recorded remote controls/radio tags/mobile device" section of the user manual for detailed description.

## PANDORA ALARM STUDIO

The Pandora Alarm Studio application allows you to change the main settings and parameters of the system, update firmware, download installation manuals, connect to the server to make CLONE procedure.

### Working with the Pandora AlarmStudio

A current version of the Pandora AlarmStudio can be downloaded from pandorainfo.com. The Pandora AlarmStudio is provided only to authorized installers of Pandora systems.

Download the Pandora AlarmStudio to a PC with Windows XP/Vista/7/8/10.

- Run the Pandora AlarmStudio;
- Connect the system to the PC via a USB cable;

been already paired and it is required to delete it for pairing a new device. To delete a device, press and hold the VALET button for 3 seconds (3 orange flashes of the LED). The system will be in pairing mode for 1 minute. After a minute or immediately after pairing a device, the system will automatically enter the programming level №0.

**NOTE!** Examples of pairing Bluetooth devices are printed on the side of this manual where the wiring diagram is shown.

- **Updating firmware of the built-in Bluetooth modem**
- **Updating firmware of an additional device**

Enter an appropriate sublevel or a cell of the PROGRAMMING TABLE and use the Pandora BT application to update firmware. To update firmware of the built-in Bluetooth modem, enter the "Level №10" ➔ "Sublevel 10". To update firmware of an additional device, enter the "Level №10" ➔ "Sublevel" or "Cell" corresponding to an additional device. The LED will light red after entering. Press and hold **(H)** the VALET button for 5 seconds. Open the Pandora BT, go to "Search device" screen and select the device and then select one of the update option:

INTERNET – It allows you to upload firmware from a server.

FILE MANAGER – This function is available only for Android devices. It allows you to upload firmware from phone storage.

### Level №11 – Programming and configuring an "Immobilizer PIN-code"

The level is divided into 3 sublevels (Sublevel

mobile device from the system memory and then pair the mobile device with the system again. Put the system in programming mode by entering the "Service PIN-code" (default value is 1-1-1-1). The system will enter the programming level №0. Press and hold the VALET button for 5 seconds (until the fifth sound signal of the beeper or the fifth orange flash of the LED) to enter the programming level №50. The LED indicator will light green after entering the programming level №50 and the system will enter the mobile device pairing mode. Turn on Bluetooth on your mobile phone and open the mobile application. Go to the search device screen and select the found system. The system will confirm the pairing with the series of green and red flashes of the LED and a sound signal of the siren. The system will return to the programming level №0.

**ATTENTION!** If there is no automatic pairing, enable the "PIN request for phone pairing" item in the "Radio tag and mobile device functions" settings in the Pandora Alarm Studio application and make the pairing procedure again. A mobile device will request a PIN-code (Factory pre-set is 0-0-1-1-1-1 where the 4 last digits 1-1-1-1 are the "Service PIN-code", it will be different if you have changed the "Service PIN-code").

### Level №100 – Exit the programming menu

**NOTE!** See the detailed description in the "MOBILE APPLICATIONS" section of the user manual.

- Put the system to the programming mode;
- The Pandora AlarmStudio will automatically connect to the system and you will be able to configure settings and update firmware. It is recommended to update firmware of the base unit before installing and programming the system:
- Open the "Update Software" window and select one of the update options ("Load from file" – upload firmware file from a PC folder, "Firmware archive" – upload firmware from a server to "firmwares" folder);
- Select firmware and press the "Update" button to upload firmware to the base unit. It is required to exit programming mode after settings were changed or firmware was updated.

**NOTE!** If boot mode has been interrupted for some reason and the status indicator lights red, you need to load firmware using quick boot mode (without entering the PIN-code). Open AlarmStudio, de-energize and disconnect the system, press and hold VALET button located on the base unit, release the button immediately after connecting the system and a computer via USB cable, the system will enter boot mode.

## PROGRAMMING TABLE

**NOTE!** The programming table is printed on the side of this manual where the wiring diagram is shown.

### Level №0 Entering a level

After entering programming mode, the system waits for level input – "Level 0 Entering a level".

11.0 – Selecting buttons; sublevel 11.1 entering the PIN-code; sublevel 11.2 – confirmation of the PIN-code input). Use the VALET button to navigate between sublevels and save the code. Enter the programming level № 11.

#### Sublevel 11.0 – Selecting buttons:

The system will automatically enter the sublevel 11.0 (Selecting buttons) after entering the level 11. The system will wait for buttons pressing. Each pressing will be confirmed with an orange flash of the LED. You can turn on the ignition (the system will stay in programming mode). Some buttons can be detected via digital bus only when ignition is on. The system can determine buttons via analog "Code immobilizer 1" and "Code immobilizer 2" inputs or via digital protocol of a car. After selecting active buttons, press the VALET button to enter the sublevel 11.1 (Entering the PIN-code).

#### Sublevel 11.1 – Entering the PIN-code:

Program the immobilizer deactivation PIN-code using the selected button or buttons on this sublevel. The code can consist of one or more memory cells, each memory cell can store a sequence of pressing each of the five selected immobilizer buttons. The code is entered by pressing the selected buttons for at least 1 second. Each pressing is confirmed with an orange flash of the LED. A pause for more than 1 second and the red LED confirms the input for the current memory cell, you can start entering the next memory cell. After entering the code, press the VALET button to enter the next sublevel.

To exit the programming menu, press and hold the VALET button for more than 10 seconds until the tenth sound signal of the Siren/Beeper or until a red flash of the LED. The system will exit programming mode and will reboot programmatically.

Enter a desired level using the VALET button (see the programming table) to change settings or parameters.

- To enter a level ("Level №1...№17"), press **(P)** the VALET button the number of times equals to the desired level number **(1...17)**, pauses between presses should not exceed 1 second. The system will confirm correct input with red LED flashes and short sound signals of the siren/beeper and proceed to the desired level. To enter a sublevel or a cell of sublevel make a pause for more than 1 second (➔), then press **(P)** the VALET button the number of times equals to the desired sublevel or cell number: "Level №10 ➔ (1sec) "Sublevel 1...**10**" ➔ (1sec) "Cell of sublevel 1...4".

- For quick access to the higher level, press and hold **(H)** the VALET button. The siren will sounds tone beeps (up to 10). These sounds means the sequence number of a two-digit level number (the first signal – level №10, the fifth signal – level №50, the tenth signal – level №100). Release the VALET button immediately after the desired number of signal. To enter an intermediate level (Level №11...№17), press the VALET button the number of times equals to the second digit (1...7) of the desired level number immediately (+) after releasing the button. The system will confirm correct input with red LED flashes and short sound signals of the siren/beeper and proceed to the desired level.

### Level №1 – Pairing remote controls

Prepare to pair all remote controls in accordance with manuals. The system will be in the remote controls pairing mode for 1 minute. After a

**№11.2 - Confirmation of the PIN-code input:** Confirm the entered PIN-code on this sublevel. Repeat the procedure described above and press the VALET button. The system will compare two inputs after that.

- If you correctly enter the code twice, the indicator will produce the series of red and green flashes and the Beeper will produce the series of sounds, the new code will be recorded, the system will return to the programming level №0.

- In case of the incorrect code input the indicator will be lit red and the Beeper will sound a long beep, the system will not change the code and will return to the programming level №0.

### Level №12 – Fuel level calibration

**NOTE!** The procedure is used only for analog connection of fuel level. To define the current fuel level, calibration should be performed at least by two points.

**ATTENTION! All functions of this level are available in the Pandora BT.**

To control fuel level, make connections and configure the settings:

- Setting is performed via the Pandora AlarmStudio. The "Use INP to control fuel level" item should be enabled in the settings, the factory setting of this input (input settings) must be unselected.
- Make a connection in accordance with the "Fuel control input" scheme. To define the current fuel level, calibration should be performed at least by two points. In some cases fuel level calibration should be performed by all specified points (for more exact definition).

minute or immediately after pairing a Bluetooth remote control, the system will automatically enter the programming level №0. 868 MHz remote controls are paired one by one, all 868 MHz remote controls that was previously paired will be removed. A Bluetooth remote control must be paired last or separately. To remove a Bluetooth remote control, press and hold the VALET button for 3 seconds on the programming level №1.

**NOTE!** The description of pairing is printed on the side of this manual where the wiring diagram is shown.

### Level №2 – Changing the Service PIN-code

**NOTE!** Prepare a new value of the "Service PIN-code, it should consist of 4 digits (from 1 to 9). Write down or remember the new PIN-code.

Enter the programming level №2.

- Enter the first digit of the code using the VALET button. Press the button the number of times equals to the first digit. Pauses between presses should not exceed 1 second, every pressing will confirm with an orange LED indicator flash. Pause for more than 1 second and a red LED indicator flash with a sound from the Beeper confirms the input of the first digit. Then you can enter the next digit;
- Enter the other numbers in the same manner. The input of the fourth number will be confirmed by the series of red and green LED indicator flashes and the series of sound signals of the Beeper. The system will wait for PIN-code

### Fuel level calibration:

- Select the desired sub-level in the table corresponding to the current fuel level (%). Enter the programming level 12. The LED indicator will be red and the system will enter to the sublevel 12-0 (0%). Enter the number of the desired sublevel (10-100%) by pressing the VALET button (press the button a number of times equals to a digit; pauses between presses should not exceed 1 second).
- Start the engine, press the lock button on the remote control no less than in 1 minute – the data will be sent to the base unit. If you want to cancel the current setting, press the unlock button
- Repeat the procedure for the second and next calibration points.
- To exit the programming mode, enter sublevel 12 or press VALET button more than 12 times.

### Reset all calibration points:

To reset all calibration values, proceed to the sublevel 11 (do not switch on the ignition). Reset confirmation is performed by pressing the lock button, exit without confirmation and exit the menu are performed by pressing the VALET button.

re-entering;

- Enter all four digits again.

- If you correctly enter the "Service PIN-code" twice, the indicator will produce the series of red and green flashes and the Beeper will produce the series of sounds, the new PIN-code will be recorded, the system will return to the programming level №0.

- In case of the incorrect code input the indicator will be lit red and the Beeper will sound a long beep, the system will not change the code and will return to the programming level №0.

### Level №3 – Recording the idle speed (rpm)

**NOTE!** To timely turn off the starter during automatic or remote engine start and the correct operation of the «Smart Turbo Timer», it is necessary to record the engine idle speed via digital or analog tachometer input.

Enter the programming level №3.

- Turn on the ignition and start the engine. Wait until the stable idle speed will be reached (the engine should be warmed-up, idle speed should match the stable idle speed of the warmed-up engine). The system will confirm the presence of the idle speed status with green flashes of LED indicator.
- Press the VALET button once to save idle speed. Successful recording of the idle speed will be confirmed with the series of red and green flashes of the LED indicator and the series of sound signals of the Beeper. The system will exit programming menu and reboot after saving the idle speed.

Sublevel	Fuel level
12-0	0%
12-1	10%
12-2	20%
12-3	30%
12-4	40%
12-5	50%
12-6	60%
12-7	70%
12-8	80%
12-9	90%
12-10	100%
12-11	Reset all calibration values
12-12	Exit programming mode

### Level №13/№15 – Emergency deactivating/activating authorization devices/functions

**NOTE!** See the detailed description in the "CONTROL OVER THE SYSTEM IN CASE OF EMERGENCY" section of the user manual.

To deactivate/activate "Code immobilizer function" (pin-to-drive), enter the programming level №13.

To deactivate/activate authorization devices (mobile phone, radio tags, Bluetooth remote control), enter the programming level №15.

#### • Deactivating the function

The LED indicator will light green after entering the programming level. The system will wait (10 seconds) for entering the 'Secret PIN-code'. If the PIN-code is not entered within 10 seconds the