

Door Sensor DMS-100BT



Wireless door sensor DMS-100BT is designed for the remote detection of shock and rotation, temperature, opening of the door that is located at a considerable distance from the base unit of car service-security system.

The following zones can be controlled with this sensor: sunroof, coffer cover, trunk, trailer, case cover for carrying some valuables and so on.

Sensor's operation is based on using of 3-coordinate accelerometer that allows detecting rotations, shocks and door motions, and on using a magnetic pair (hall sensor) for reliable detection of door opening/closing.

Installation

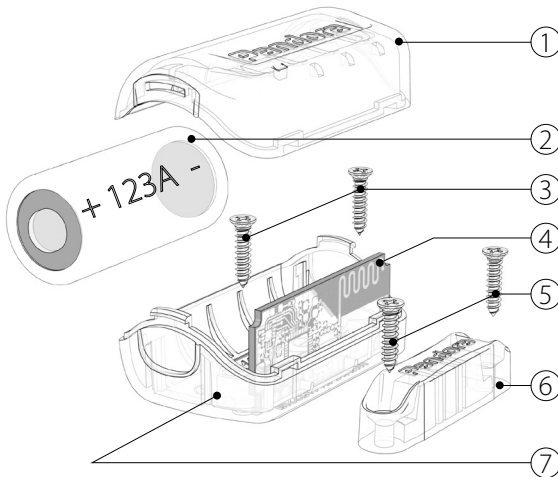

Open cover 1 of the base unit, remove the battery 2 and then attach cover 7 of the base unit with screws 3 to the door's movable part.

Attach magnetic unit 6 with screws 5 to the door's fixed part in a way to match magnetic unit 6 with the sensor's base unit, magnetic sensor 4 (see picture) when closing door.

Gap must not exceed 5 mm similar to the standard reed sensor.

Programming sensor

1. Remove the sensor's battery.
2. Enter programming level 23-24 on a security system; LED indicator will be lit green.
3. Insert the battery into the sensor. Successful programming of the sensor to the system's memory will be confirmed with a sound signal of the siren, red LED flash of the system and sensor's indicator green flash.

Firmware update of the sensor

Firmware update is performed on the 25-26 programming level of a security system.

Replacing the battery

Open cover 1 of the base unit, remove battery 2 and insert the new one, respecting the polarity.

Compatibility

Pandora Light Pro, Pandora Smart Pro, Pandora Mini

Specifications

Battery	123A
Radio interface	2,4 GHz Bluetooth
Power consumption in active mode	up to 30uA
Operating time from the battery	up to 12 months

Manufacturer reserves the right to change set and construction of the product to improve its technological and operational parameters without notification.

pandorainfo.eu