

**Pandora would like to thank you
for choosing our service-security system
Pandora Light v3**

Pandora Light v3 is a car service-security system built for cars with on-board voltage of 12V. It is a complex engineering device, which includes unique and modern technological software and hardware solutions.

While developing the Pandora Light v3 we were using the most up-to-date electronics from world's best manufacturers. The device is built using high-precision mounting and control machinery, thus we guarantee highest possible quality, reliability and stable technical characteristics for the whole operation period.

The system has a cryptographically strong authorization code with unique dialog algorithm and individual encryption key on every device. It guarantees protection from electronic hacking for the whole operation period.

The system is built for your convenience: it's ergonomic, reliable, has the highest security and service characteristics, 3 years unconditional warranty and free service and support. We are happy to provide any support we can – feel free to use our online support.

! WARNING! IT'S STRONGLY RECOMMENDED TO INSTALL A SECURITY SYSTEM BY THE QUALIFIED PERSONNEL!
THE INSTALLER SHOULD BE ABLE TO MOUNT THE SYSTEM USING PROVIDED DOCUMENTATION – INSTALLATION DIAGRAM, SPECIFIC INSTALLATION GUIDES AND SPECIAL SOFTWARE DEVELOPED AND TESTED BY OUR ENGINEERS. MOST OF THE FEATURES ARE DEPENDS OF A CORRECT CONNECTION AND CONFIGURATION OF THE SERVICE-SECURITY SYSTEM, SO IF THE CERTAIN FEATURE DOESN'T WORK AS EXPECTED, MOST LIKELY THE PROBLEM IS RELATED TO IMPROPER INSTALLATION.

This device has limited external factors resistance. It should be operated in temperatures outside from -40 to +85°C range. All system components must be installed only in a car interior. The base unit and radio tags fulfil with the IP40 category of protection against water.

**Our web-site: pandorainfo.com
Customer support: support@pandorainfo.com**



Product is in conformity with Electromagnetic Compatibility
Directive EMC 2004/108/EC and R&TTE Directive 1999/5/EC

Table of contents

General information	4
System set	4
Read before using	5
PIN-codes of the system	6
Owner's personal card	6
External VALET button	7
System modules layout	7
Base unit	8
Information signals of the system	9
System functions and modes	11
Security mode	11
Control and security zones	11
Remote and automatic engine starts	12
Slave mode	13
Code immobiliser (pin to drive) function	14
Beach mode	14
Checking the number of paired devices	15
Remote control D-010	16
Switching on/off remote control	16
Meaning of the LED SEND/ALARM indicator signals	17
Replacing the remote control battery	17
Quick access functions	18
Icons of the remote control	19
Engine heater. Time channels	22
Check car status	23
Event history. Automatic engine start	24
Shock/motion/tilt sensor settings	27
System installation	30
General installation requirements	30
Base unit connectors description	31
Wiring diagram	32

Remote control D-010	35
Siren signal settings	37
Sound notification settings	38
Radio channel control settings	38
Service/Valet mode	39
Time settings. Alarm clock settings	40
Control the system	41
Arming	41
Disarming	42
Unlocking the trunk	42
Locking/unlocking doors when ignition is on	43
Delayed arming	43
Car search function	44
PANIC mode	44
Remote engine start	45
«Hold On» mode	46
Engine preheater	46
Service mode	47
Control over the system in case of emergency	48
Emergency disarming/Beach mode off	49
Emergency control of the code immobiliser	50
Programming the system	51
Additional devices	57
Warranty obligations	59
Installation certificate	63
Acceptance certificate	64
Warranty Card	64

GENERAL INFORMATION

System set

1. User and installation manual	1
2. Owner's personal card	1
3. Main remote control D-010	1
4. Additional remote control R-387	1
5. Base unit	1
6. External VALET button	1
7. External temperature sensor	1
8. Relay module RMD-5M	1
9. Main cable of the base unit	1
10. LIN-interface cable	1
11. IMMO-KEY interface cable	1
12. Fastening kit	1
13. Packaging	1

NOTE! THE MANUFACTURER RESERVES THE RIGHT TO CHANGE THE SYSTEM SET AND CONSTRUCTION OF THE PRODUCT TO IMPROVE IT'S TECHNOLOGICAL AND OPERATIONAL PARAMETERS WITHOUT NOTIFICATION.

Read before using

Carefully read this manual before starting installation and using the security-service system. Pay attention to text marked with **!**

! THE SECURITY-SERVICE SYSTEM IS A COMPLEX TECHNICAL PRODUCT. SYSTEM INSTALLATION AND CONFIGURATION MUST BE CARRIED OUT ONLY BY A SKILLED PROFESSIONAL.

! FEATURES AND SYSTEM MODES, CONTROL OF THE VEHICLE'S ZONES DEPENDS ON THE TYPE OF CONNECTION AND SYSTEM SETTINGS, ORIGINAL VEHICLE OPERATION LOGIC AND TRIM.

! THE SYSTEM SET INCLUDES THE «OWNER'S PERSONAL CARD». THIS CARD CONTAINS INFORMATION UNDER THE PROTECTIVE LAYER THAT IS INTENDED ONLY FOR THE OWNER OF THE SYSTEM. MAKE SURE THAT THE PROTECTIVE LAYER ON THE OWNER'S PLASTIC CARD IS INTACT AFTER THE INSTALLATION OF THE SYSTEM. READ THE «OWNER'S PERSONAL CARD» SECTION OF THIS MANUAL BEFORE ERASING THE PROTECTIVE LAYER.

! WHEN SYSTEM INSTALLATION IS FINISHED:

- CHECK THE SYSTEM OPERATION AND FUNCTIONS WITH A SPECIALIST. WE RECOMMEND THAT YOU MARK EACH WORKING FUNCTION WITH A SIGN IN THE «CONTROL THE SYSTEM» SECTION.
- CHECK THAT THE «INSTALLATION CERTIFICATE» AND «WARRANTY CARD» ARE FILLED OUT. THESE DOCUMENTS MAY BE REQUIRED FOR CONTACTING THE CUSTOMER SUPPORT.
- ASK AN INSTALLER TO MARK THE LAYOUT OF THE SYSTEM COMPONENTS ON THE DIAGRAM. THIS INFORMATION MAY BE REQUIRED FOR DIAGNOSTIC/CONFIGURING OR EMERGENCY DEACTIVATION OF THE SYSTEM.
- WE RECOMMEND THAT YOU CHANGE THE DEFAULT VALUE OF THE PIN-CODES OF THE SYSTEM. YOU CAN WRITE DOWN THE CHANGED PIN-CODES IN THE «PIN-CODES OF THE SYSTEM» SECTION.

PIN-codes of the system

The «Secret PIN-code»

(is written on the «Owner's personal card»)

The «Service PIN-code»

(default value is 1-1-1-1)

The «Immobiliser PIN-code»

(is used for the Code Immobiliser (pin-to-drive) function)

The «Beach mode PIN-code»

(is used with «Beach mode» enabled)

CANNOT BE CHANGED			
□	□	□	□
□	□	□	□
□	□	□	□

! IT IS RECOMMENDED THAT YOU WILL WRITE DOWN THE CHANGED OR CREATED VALUES OF ALL PIN-CODES. ELIMINATE THIRD-PARTY ACCESS TO THIS INFORMATION.

Owner's personal card

! ERASE THE PROTECTIVE LAYER CAREFULLY. DO NOT USE ANY SHARP OBJECTS TO AVOID DAMAGING OF HIDDEN INFORMATION UNDER THE PROTECTIVE LAYER. THE INFORMATION ON THE OWNER'S PERSONAL CARD COULD NOT BE CHANGED OR RESTORED IN CASE OF DAMAGE OR LOSE.

The owner's personal card contains private information under a protective layer:

- **PIN (the «Secret PIN-code»)** is a 4-digit number. This code can be used to disarm the system and to deactivate immobiliser functions and to activate service mode. It can be also used to enter programming mode.
- **LOGIN/PASS/ Phone number** - not used.

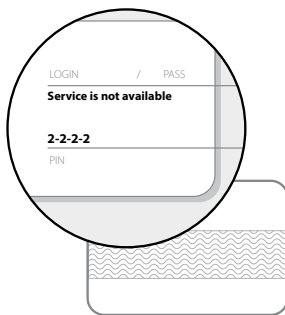

External VALET button

An external VALET button with a three-color (red, green, orange) status LED indicator is placed inside a vehicle (see the system modules layout). The button is used for programming the system, arming/disarming, activating/deactivating immobiliser mode.

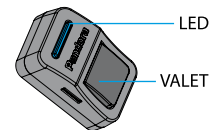

System modules layout

- 1 External VALET button (VALET button via CAN)
- 2 Button for the immobiliser PIN
- 3 Button for the «Beach mode» PIN
- 4 Circuit being blocked
- 5 Base unit
- 6
- 7
- 8

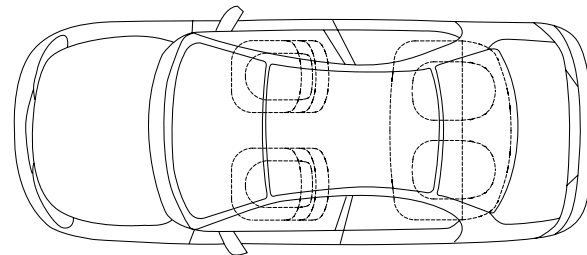
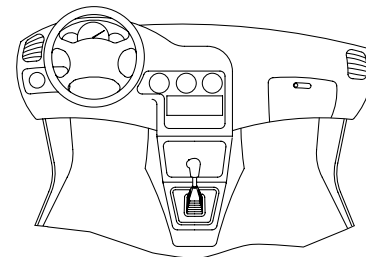

Base unit

868MHz Antenna (dynamic dialog encryption AES 128 bit) supports up to 4 remote controls D-010, DXL-707/078/077, R-387.

Built-in 3D accelerometer is used to detect shock/motion/tilt including 2 separate zones of shock sensor (alarm and warning), the system allows to adjust sensitivity of each zone, to use data from the accelerometer to block the engine and close the central lock on movement.

Temperature sensors allow the system to measure temperature of different zones to send this information to the remote control. The following zones are available: interior temperature – built in sensor of the main unit, engine temperature – external temperature sensor (see the «System set»). The system setting allows you to reassign sensor to different zones and to implement automatic engine or engine preheater starts and stops by temperature.

Built-in digital 2xCAN/LIN* interfaces allow the system to read status and execute commands via digital buses, and work with Webasto Thermo Top Evo и Eberspacher Hydronic 1/2/3.

Built-in digital IMMO-KEY port and immobiliser bypass* – hardware and software algorithms with the special Pandora CLONE server allow the system to bypass original immobilisers for automatic and remote engine starts.

Built-in micro-USB port – update and configuration of the system using Pandora Specialist mobile app or Alarm Studio program.

 *MORE INFORMATION IS AVAILABLE ON LOADER.PANDORAINFO.COM

Information signals of the system

LED INDICATOR SIGNALS	
SIGNALS	DESCRIPTION
THE SYSTEM IS ARMED	
Short red flashes	System is armed
Fast red flashes	Alarm
THE SYSTEM IS DISARMED	
Faded	System is disarmed
Red	System is preparing for automatic or delayed arming
Green (when ignition is on)	System is in service mode
Orange flashes (when switching on the ignition)	Confirms the number of paired remotes
WHEN ENTERING THE «SECRET PIN-CODE» OR THE «SERVICE PIN-CODE»	
Orange flash	Confirms a VALET button press
Short red flash	Confirms a digit input PIN-code is incorrect
Red and green flashes	Confirms correct PIN code

SOUND AND LIGHT SIGNALIZATION	
SIGNALS (sound / light)	DESCRIPTION
1x / 1x	Arming
2x / 2x	Disarming
5x / 5x	Car search
30sec. / 30sec.	Alarm - alarm level of a sensor is triggered, PANIC mode
3x	Remote/automatic engine start procedure indication
3x / 1x	Warning level of a sensor is triggered
4x / 4x	«Sensors were triggered» signal when disarming Parking light is not turned off notification «Sensors are triggered» signal when arming

BEEPER SOUND SIGNALS	
SIGNAL	DESCRIPTION
1 sound signal	Activating service mode
2 sound signals	Deactivating service mode
1 sound signal	Correct input of the «Immobiliser PIN-code»

SIREN AND BEEPER ARE NOT INCLUDED IN THE SYSTEM SET.

SYSTEM FUNCTIONS AND MODES

Security mode

The system confirms arming with 1x sound and 1x light signals. When the system is armed, the system monitors security zones with separated warning and alarm level of triggering:

- Warning mode - this mode activates when there is a slight impact on the shock sensor or additional sensor. It is accompanied with 1x light and 3x sound signals;
- Alarm mode - this mode activates when a sensor or one of the security zones is triggered. It is 30 sec. light and 30 sec. sound signals. The alarm signals can be cancelled by an arming or disarming command.

If one of the security zones is triggered the system:

- records this event in its non-volatile memory;
- activates the alarm or warning mode;
- informs an owner by all available means;
- blocks the engine (in accordance with the settings and connections).

If one of the security zones is opened at the moment of arming, the system will produce 4x sound and 4x light warning signals.

If one of the security zones fails, the system will forcibly turn off this zone. If a switch triggers more than 9 times in a row, it will be disabled until the next arming. The shock/tilt/motion sensor is temporarily deactivated (15 sec.) if it has been triggered more than 3 times in a row.

The system confirms disarming with 2x sound and 2x light signals. The system deactivates engine blocking (if the immobiliser function and additional blocking are not used). If there were alarm events (except warning level) during the armed period, the system will produce 4x sound and 4x light warning signals. The system continues to display all zones when it is disarmed, but the information is not saved in the memory.

THE SYSTEM CONTINUES TO DISPLAY ALL ZONES WHEN IT IS DISARMED, BUT THE INFORMATION IS NOT SAVED IN THE MEMORY.

Controlled and security zones

- Interior temperature (status)
- Engine temperature (status)
- Voltage of the on-board circuits (status)
- Engine operation control - RPM (status)



- Heater operating control (status)
- Fuel level (status)
- Parking (automatic gearbox) /Handbrake (manual gearbox) status
- Parking light is not turned off notification (status)*
- Shock sensor (security zone – alarm and warning level)
- Motion sensor (security zone – alarm level)
- Tilt sensor (security zone – alarm level)
- OE alarm system status*, additional sensor** (status, security zone – alarm and warning level)
- Turning ignition on (status, security zone – alarm level)
- Opening doors (status, security zone – alarm level)
- Opening a hood (status, security zone – alarm level)
- Opening a trunk (status, security zone – alarm level)
- Pressing brake (status, security zone – alarm level)

* AVAILABLE VIA CAN-BUS (SEE LOADER.PANDORAINFO.COM)

** OPTION (NOT INCLUDED IN THE SYSTEM SET).

Remote and automatic engine starts

The system allows the remote engine start using the “remote engine start” command from a remote control or preconfigured automatic engine start function. Remote start can be used to heat engine and interior, charge battery or to cool the interior with air conditioning.

Remote and automatic starts can only be used when the system is armed . While the system is in remote or automatic start mode, it keeps performing all security functions of all security zones excluding a shock sensor  and additional sensor  (the system can be configured not to disable sensors during a remote engine start). To compensate it, the motion sensor sensitivity will be increased and its responsiveness will be reduced. If any security zone will be triggered, the engine will be immediately stopped and alarm mode will be triggered.

When using the remote and automatic engine start functions, make sure that a car is secured with handbrake or some other means of fixing the car on a parking position.

Remote and automatic engine start on automatic transmission cars will only occur, if a transmission selector lever was left in the «P» position.

If a car has manual transmission, remote or automatic start will only occur if the program neutral procedure was followed when the car was arming.

An example of the program neutral procedure

1. When the engine is running, fixate the car with the handbrake and put gear lever to the neutral position. Program neutral procedure will be switched on automatically (by default system settings).
2. Turn the key in the ignition lock to the OFF position (the engine should still be running) and take it out of the lock (skip this step for cars with a Start/Stop button).
3. Leave the car, close the doors.
4. Arm the system - the engine will be stopped. Now the system is ready to perform remote and automatic engine start.

Automatic starts

The system allows configuring automatic engine start and stop conditions using a remote control. The following conditions can be specified for automatic engine starts: schedule, time period, engine temperature, voltage. The engine will be stopped automatically after specified time or when the engine temperature reaches a specified value. The engine can be also stopped by a user command.

 AUTOMATIC ENGINE STARTS AND STOPS BY TEMPERATURE ARE AVAILABLE ONLY IF ENGINE TEMPERATURE DATA IS AVAILABLE IN DIGITAL BUSES OF THE CAR, OR IF AN EXTERNAL ENGINE TEMPERATURE SENSOR IS CONNECTED. REMOTE AND AUTOMATIC ENGINE STARTS ARE NOT AVAILABLE IF THE HOOD IS OPEN.

AFTER A SERIES OF THREE UNSUCCESSFUL ATTEMPTS OF AUTOMATIC START, ALL FOLLOWING AUTOMATIC STARTS WILL BE CANCELED UNTIL DISARMING/ARMING (THIS DOES NOT AFFECT ON REMOTE ENGINE START).

Slave mode

This mode allows arming and disarming vehicle control elements – factory key fob, buttons/sensors of a keyless access entry system.

Slave mode can be implemented using analog connections or a digital protocol of a vehicle.

 THIS MODE IS DISABLED BY DEFAULT - CONFIGURATION OF THE SYSTEM SHOULD BE MADE BY A QUALIFIED TECHNICIAN. TO INCREASE THE ANTI-THEFT FUNCTIONALITY OF THE SLAVE MODE IT IS RECOMMENDED TO USE THE DISABLE ENGINE BLOCKING FUNCTION WHEN «IMMOBILISER PIN-CODE» ENTERED (SEE CODE IMMOBILISER (PIN TO DRIVE) FUNCTION)

Code immobiliser (pin to drive) function

This function allows to use the pre-programmed «Immobiliser PIN-code» to disable the engine blocking, service mode, disarming the security system. The code must be entered using factory vehicle controls (buttons/lever/pedal) and/or additionally installed elements.

In case of emergency it is possible to disable code immobiliser by methods, described in «Control the system in case of emergency».

AN EXAMPLE OF USING THE FUNCTION

- Turn on the ignition to disable engine blocking or service mode, turning on the ignition is not required if you want to disarm the system or control time channels.
- Enter the «Immobiliser PIN-code», code can consist max of 4 digits from 1 to 9.
 - Press the pre-programmed button/lever/pedal the number of times equals to the first digit.
 - Pauses between presses should not exceed 1 second. More than 1 second pause will be interpreted as the start of the next digit input.
- The system will confirm the correct input by a sound signal of the beeper and will activate a programmed action.

 THIS MODE IS DISABLED BY DEFAULT - CONFIGURATION OF THE SYSTEM SHOULD BE MADE BY A QUALIFIED TECHNICIAN. EMERGENCY DISABLING OF THE CODE IMMOBILISER IS MADE WITH THE «SECRET PIN-CODE» AND VALET BUTTON (SEE «DEACTIVATING CODE IMMOBILISER (PIN-TO-DRIVE)»).

Beach mode

This mode allows to use the pre-programmed «Beach mode PIN-code» for system arming/disarming. The code must be entered using factory vehicle controls (buttons/sensors) or additionally installed element.

When using the Beach mode system disarming is possible only by entering «Beach mode PIN-code» or «Secret PIN-code» by a VALET button (see «Control the system in case of emergency»)

AN EXAMPLE OF USING BEACH MODE

- Press the factory or additionally installed element until the single light flash, thereafter start to enter «Beach mode PIN-code».
- Enter the «Beach mode PIN-code», code can consist max of 4 digits from 1 to 9:
 - Press the the control element the number of times equals to the first digit.
 - Pauses between presses should not exceed 1 second. More than 1 second pause will be interpreted as the start of the next digit input.

- After the correct input the system will confirm arming/disarming by the sound and light signals.

 THIS MODE IS DISABLED BY DEFAULT - CONFIGURATION OF THE SYSTEM SHOULD BE MADE BY A QUALIFIED TECHNICIAN. EMERGENCY DISABLING OF THE SYSTEM IS MADE WITH THE «SECRET PIN-CODE» AND VALET BUTTON (SEE «CONTROL THE SYSTEM IN CASE OF EMERGENCY»)

Checking the number of recorded remote controls

The number of recorded remote controls can be checked by the number of flashes of the LED indicator on the VALET button or on the base unit. The number of registered remote controls device can be checked every time the ignition is switched on when the system is disarmed. The number of orange LED flashes will indicate the number of recorded remote controls.

You can also check the number of recorded remote controls by taking off and putting back on battery terminal. The system will emit short sound signals from a siren , with less than 1 sec. interval. The number of the signals equals to the number of recorded remote controls.

REMOTE CONTROL D-010

A two-way remote control is a mean to control and display system and vehicle state. The remote control operates only when it is in the coverage zone of the system radio channel.

All transmitted commands are reliably protected against electronic hacking with a modern dynamic dialogue encryption algorithm. For easily distinguishable notifications the remote uses 16 ringtones. Each ringtone matches a particular event. Remote has flashing LED indicators for additional information.



Switching on/off the remote control

The remote is fully operational when shipped. To switch on the remote, press and hold the **F** button for 3 seconds. The «REMOTE ON» ringtone will play (change the battery if the remote control does not switch on). Pressing and holding this button again for 3 seconds will cause the remote to switch off.

! ALL CONTROL COMMANDS ARE TRANSMITTED VIA RADIO CHANNEL, FOR MAXIMUM EFFECTIVENESS AND RANGE IT IS RECOMMENDED NOT TO SHIELD ANTENNA (SEE PICTURE) WITH FINGERS WHEN USING A REMOTE CONTROL.

Meaning of the LED SEND/ALARM indicator signals

Green indicator «SEND»:

- Flashes if there is a connection with the base unit
- Goes dark when there is no connection with the base unit.

Red indicator «ALARM»:

- Flashes frequently if there is any notification
- Flashes occasionally when there is no connection.

Replacing the remote control battery

If high quality batteries are used, service-security system remote can function up to 4 months without needing a replacement. Battery needs to be replaced if the remote control is not turning on or the icon  has only one bar left and starts flashing.















To change the battery:

- move the battery cover in the direction of the arrow;
- remove the battery from the battery compartment and, observing the polarity, insert a new one;
- close the battery cover;
- the remote is ready for use (switch the remote on by pressing **F** for 3 seconds).

! IT IS RECOMMENDED TO HAVE A SPARE AAA BATTERY IN THE CAR.



Quick access functions of the remote control

	System is disarmed		System is armed (no alarm events)
	Ignition is switched on	Ignition is switched off	
 (short press)	Lock doors without arming	Arming with sound confirmation	Search mode – flashes of turn signals with sound signals for 5 seconds
 (1 sec.)		Arming without sound confirmation	Search mode – flashes of turn signals without sound signals for 5 seconds
 (2 sec.)	Switch on «Hold On» mode		
 (3 sec.)	Switch on «Programmed neutral»		Remote engine start
 (short press)	Unlock doors	Unlock doors	Disarming with sound confirmation
 (1 sec.)			Disarming without sound confirmation
 (>2 sec.)	Switch off «Hold On» mode		Switch off the ignition during remote or automatic engine start procedure.
 (short press)	Switch on display		
 (1 sec.)	Unlock trunk		
 (2 sec.)	Switch on/off time channel		
 (3 sec.)	Switch on/off remote		
 (short press)	PANIC mode		
 (short press)	Arming when the engine is running with sound confirmation	Arming in 30 seconds with sound notification	
 (1 sec.)	Arming when the engine is running without sound confirmation	Arming in 30 seconds without sound notification	

Icons of the remote control

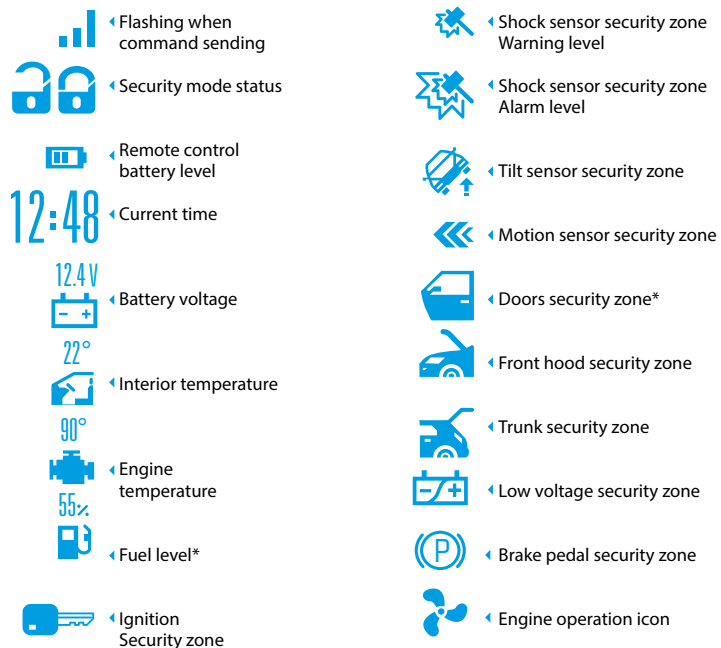



*Separate display indication of doors, factory alarm status, engine temperature depends on the information in CAN-bus digital protocol of specific car. Fuel level indication depends on the information in CAN-bus digital protocol, or on the fuel level sensor analog output signal (require additional connection).

Remote control menu

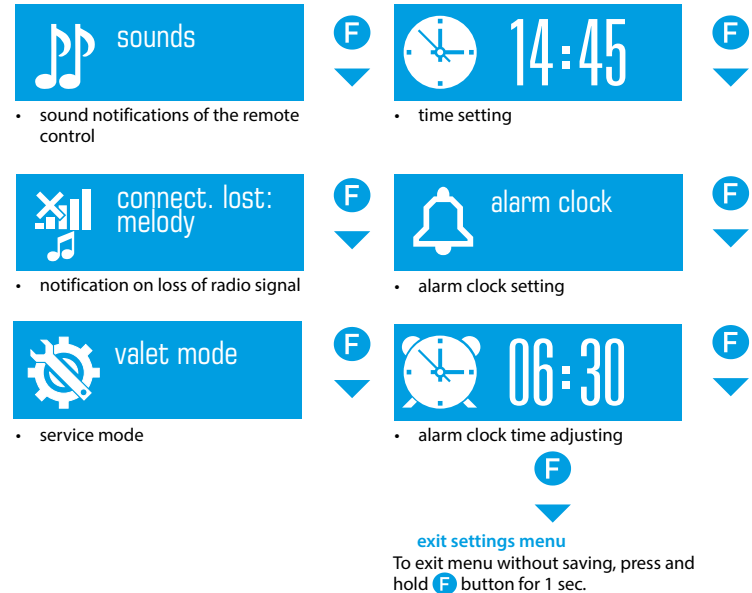
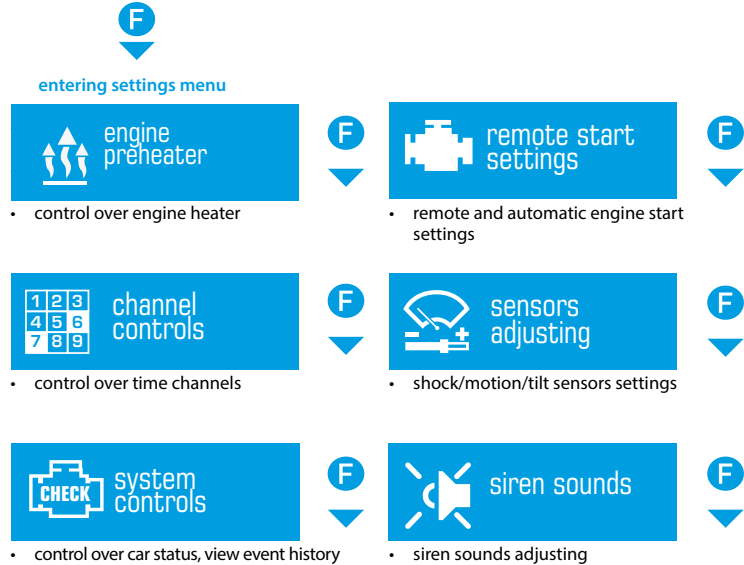
Briefly press the **F** button to enter the menu. The following presses of the **F** button will switch between menu items.



Engine heater

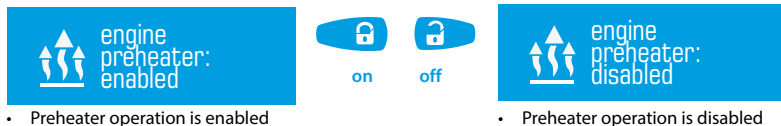

To switch on engine preheater, select «ENGINE PREHEATER MENU» and shortly press  button. To switch off preheater, shortly press  button. If preheater monitoring is enabled, LCD will display  icon during engine preheater operation.



 IT IS NECESSARY TO MAKE ADDITIONAL CONNECTIONS TO CONTROL THE ENGINE HEATER.

Time channels

Time channels can be used to implement additional functions and to control external devices.

To enter «CHANNEL CONTROLS», shortly press  button. The following presses of  button will cause switching between channels. To activate/deactivate the channel, shortly press .

To exit menu without saving, press and hold  button for 1 second.

 IT IS NECESSARY TO MAKE ADDITIONAL CONNECTIONS TO CONTROL TIME CHANNELS.

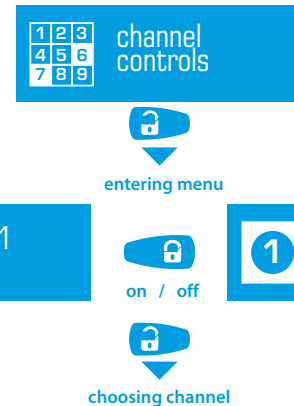

- shortly press  button to switch between channels 2,3 and 4.

Check car status

To receive information about engine, interior temperature, battery voltage and fuel level, select «SYSTEM CONTROLS» menu and shortly press  button.

To exit menu without saving, press and hold  button for 1 second.

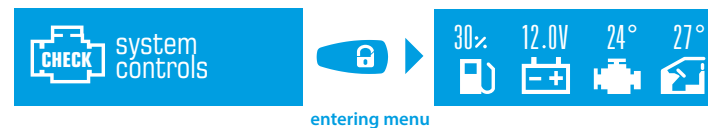

Event history

To view event history in the system's memory, select «SYSTEM CONTROLS» menu, then shortly press **ENTER** button.

Navigate several last events using **RIGHT** (forward) and **LEFT** (back) buttons. Events are displayed by showing time of the event and flashing corresponding trigger zone indicators.

To exit menu without saving, press and hold **F** button for 1 second.

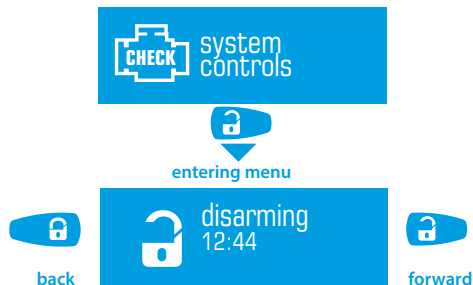

Automatic engine start

Shortly press **ENTER** button to enter «REMOTE START SETTINGS» menu. Shortly press **F** button to switch between menu sublevels. Sub-level values are changed using **RIGHT** and **LEFT** buttons.

When the settings are changed, the values should be saved. To do this, press **F** button to move to «SEND» sublevel and press **ENTER** button to save new changes. Changes will be sent to the base unit, it will be confirmed with double sound signal of the remote.

To exit menu without saving, press and hold **F** button for 1 second.

! IF YOU HAVE NOT SAVED NEW SETTINGS, REMOTE AND AUTOMATIC ENGINE START SETTINGS WILL REMAIN THE SAME AS BEFORE.

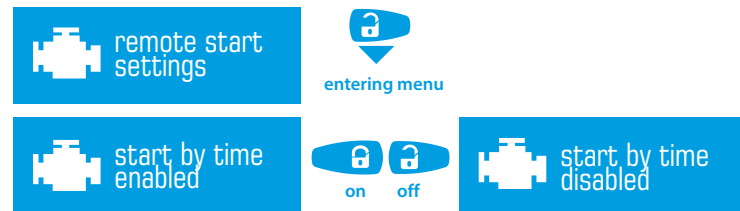

- enable/disable daily automatic engine starts by time. Set the start time in «START TIME» menu



- setting automatic engine start time for daily starting

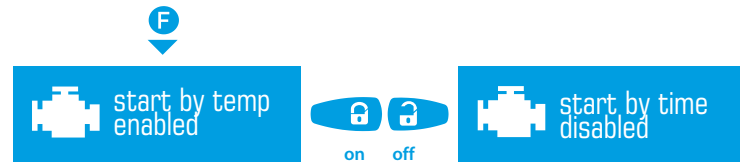

- enable/disable automatic engine start by engine temperature sensor. Set the starting temperature in «START TEMP» menu



 start temp
- 20°

increase   decrease

- setting the starting temperature for the automatic engine start



 work duration
20 min

increase   decrease

- setting the engine work duration for the remote and automatic engine start



 daily start enabled

 on  off

 daily start disabled

- enable/disable repeating engine starts after period of time (default value is 2 hours). Set the period time in the settings of the main unit



 stop by temp enabled

 on  off

 stop by temp disabled

- enable/disable the setting that allows to stop remote or automatic engine start when engine temperature increases. Set the engine stop temperature in «STOP TEMP» menu.



 stop temp
80°

increase   decrease

- set the engine stop temperature





 send settings

 set selected modes



return to the beginning of the settings

Shock/motion/tilt sensor settings

To enter the remote sensor adjusting menu shortly press  button and choose «SENSOR ADJUSTING» menu and shortly press  button.

Shortly press  button to switch between menu sublevels of the shock/motion/tilt sensors. The sensitivity of a sensor are increased using  button and decreased using  button. Maximum sensitivity value is 50 and minimum is 0.

Press and hold  button for 1 second to save new sensitivity level.

 sensors adjusting

 shortly press to enter menu

Additional sensor settings

For a prompt remote adjusting of the additional sensor control, select «ADD. SENSOR» submenu by short presses of **F** button. Short presses of the **🔒** button will cause switching between modes. To save new settings of values of the additional sensor control, shortly press **🔒** button.

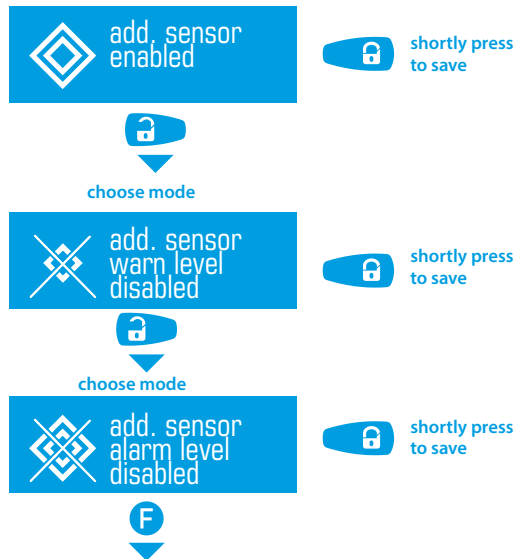

For a prompt remote adjusting of the additional sensor security zones, select «ADJUSTING ADD SENSOR WARN LVL» or «ADJUSTING ADD SENSOR ALARM LVL» submenu by short presses of **F** button. Sensor sensitivity can be set with short presses of **🔒** and **🔒** button.

To save new settings of the sensor, press and hold **🔒** button for 1 second. To exit menu without saving, press and hold **F** button for 1 second.

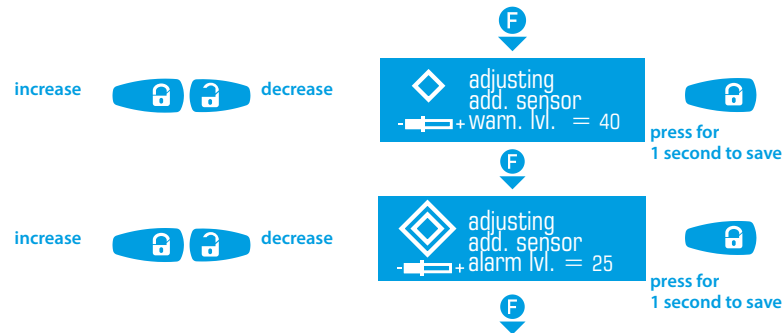

Shock sensor settings

For prompt remote adjusting of shock sensor control, select «SHOCK SENSOR» submenu by short presses of **F** button. Short presses of **🔒** button will cause switching between modes. To save new settings of values of the shock sensor control, shortly press **🔒** button.

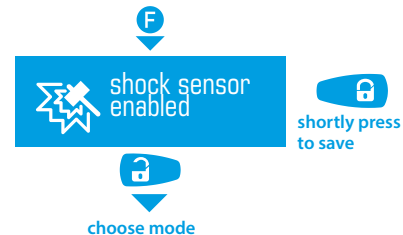

SYSTEM INSTALLATION

General installation requirements

- Install the base unit only inside car interior.
- Install securely each system's component, as conditions of the car standard operation can harm functionality of the alarm system and cause damage to the car's systems, including the elements of safety in motion.
- The system installation should be performed when the system base unit connectors and the negative battery terminal are disconnected.
- The base unit power supply should be switched off when connecting to CAN-bus. The system installation can be performed via twisting together or via lead tin soldering followed by isolation of a connection points.
- When connecting the wires together, pay attention to cross-sections and materials of connected conductors, if they are different, bring electrochemical potentials to the minimal difference. The isolation should not allow for moisture to reach wiring, as the presence of moisture will increase electrochemical destruction of wires (this is especially important for the high-current circuits).
- Connection points should be placed as high as it is possible so water condensate will not form drops on them.
- To avoid the destruction of compounds by car vibration, ensure that there is a bit of free length to the wiring, providing enough sagging.
- Do not allow wiring in places where the wires isolation can be damaged by abrasion.
- Electronic system units should be placed connectors down and as high as possible to avoid condensate reaching electronic components through the connectors.
- When installing base unit, secure it to the car body for correct operation of in-built shock sensor.
- All unused system wires during the installation must be insulated and secured to prevent accidental touching of a car body or other wires.

Base unit connectors description

X1 connector (LIN)

This connector is used for connection to the vehicle's digital buses or digital control lines of the engine heater/pre-heater Webasto Thermotop EVO and Eberspacher Hydronic 1/2/3.

X2 connector (micro-USB)

This connector is used for system setting and software update of the main unit using Pandora Alarm Studio program or Pandora Specialist (Android) mobile application.

X3 connector (Analog temperature sensor)

This connector is used to connect external temperature sensor. In the system settings it has a default value «External analog» with the logic «Engine temperature». Sensor could be reassigned to determine the interior temperature.

X4/X5 connector (Main and additional connector of the main unit)

The main connector contains low-current programmable channels, inputs «INP» and outputs «CH». Changing of the default logic is available in the system settings «Inputs and Outputs» or «Time channels». Additionally, in the «Input settings» section it is possible to change the «INP» channels from the normally open «NO» type (the system reacts on the appearance of the potential) to the normally closed «NC» type (the system reacts on the disappearance of the potential).

X6 connector (External VALLET button)

The connector is used to connect external VALET button.

X7 connector (Multifunctional port)

This connector contains multifunctional programmable channels used for implementing input «INP» logic or implementing of the bypass procedure of the original immobiliser «IMMO-KEY». Deselect any logic of the inputs «INP» in the settings if the bypass procedure implementing. The immobiliser bypass procedure must be implemented according to the installation schemes available on loader.pandorainfo.com, Pandora Alarm Studio, Pandora Specialist.

Pandora model: LIGHT v3

When implementing a bypass procedure using IMMO-KEY port it is necessary to disable any logic on INP1 and INP7 (default logic for INP1 - «Trunk switch»).

WARNING! Before starting the installation of the system: check the connection points on loader.pandorainfo.com, Pandora Specialist, Pandora Alarm Studio, update system firmware, choose a car model if connecting to CAN-bus.

WARNING! The base unit and system elements must be installed in places with appropriate temperature, moisture and dust protection characteristics (IP40 - interior, IP54 and higher - interior, engine compartment).
WARNING! All power circuits of additional devices that are not powered through the base unit of the system should have their own fuses.

WARNING! The security system is a maintenance-free device. In case of failure you must immediately contact local specialized service center.
IT IS FORBIDDEN to install the system on a car with normal voltage other than 12V.
IT IS FORBIDDEN to install the security system with damaged output cables.
IT IS FORBIDDEN to exclude or change the nominal of the fuses provided with the security system when connecting to the vehicle's wiring.

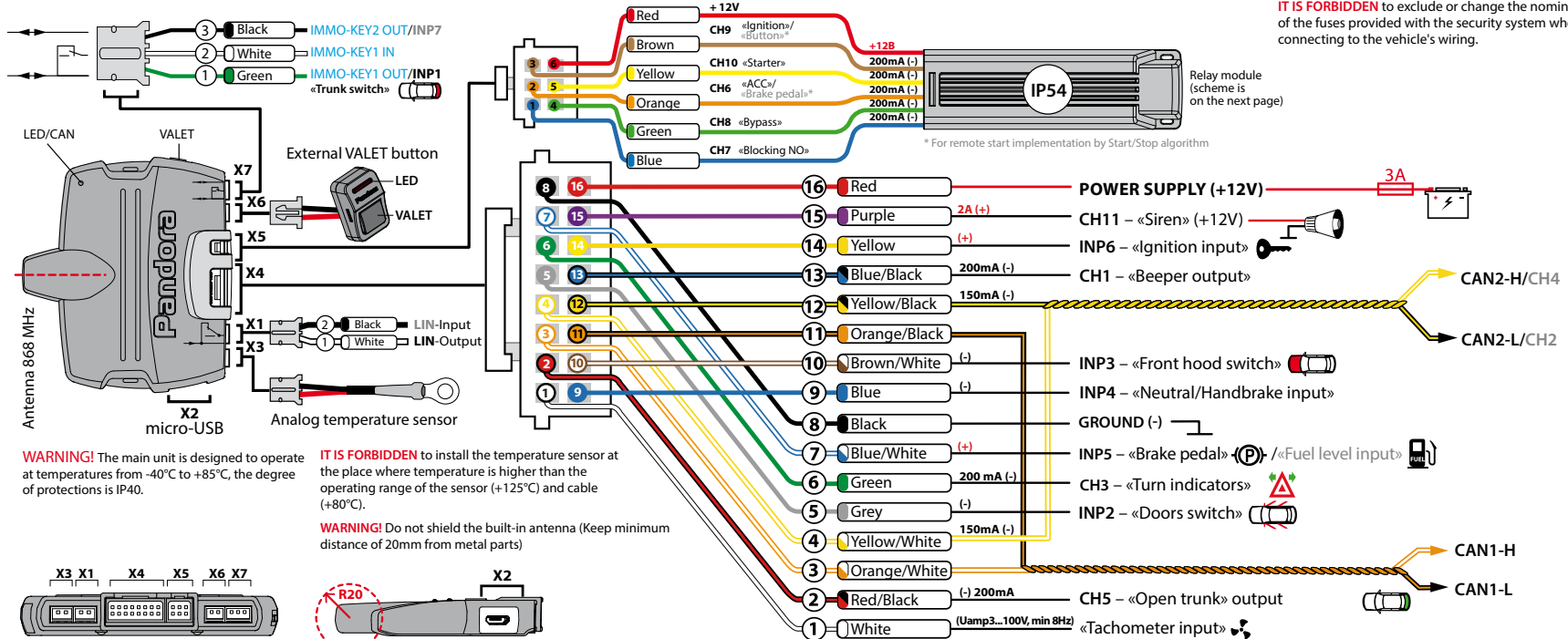

WARNING! The main unit is designed to operate at temperatures from -40°C to +85°C, the degree of protections is IP40.

IT IS FORBIDDEN to install the temperature sensor at the place where temperature is higher than the operating range of the sensor (+125°C) and cable (+80°C).

WARNING! Do not shield the built-in antenna (Keep minimum distance of 20mm from metal parts)

Pandora

Relay module RMD-5M

WARNING! The relay module RMD-5M is designed to operate at temperatures from -40°C to +85°C, the degree of protections is IP54.

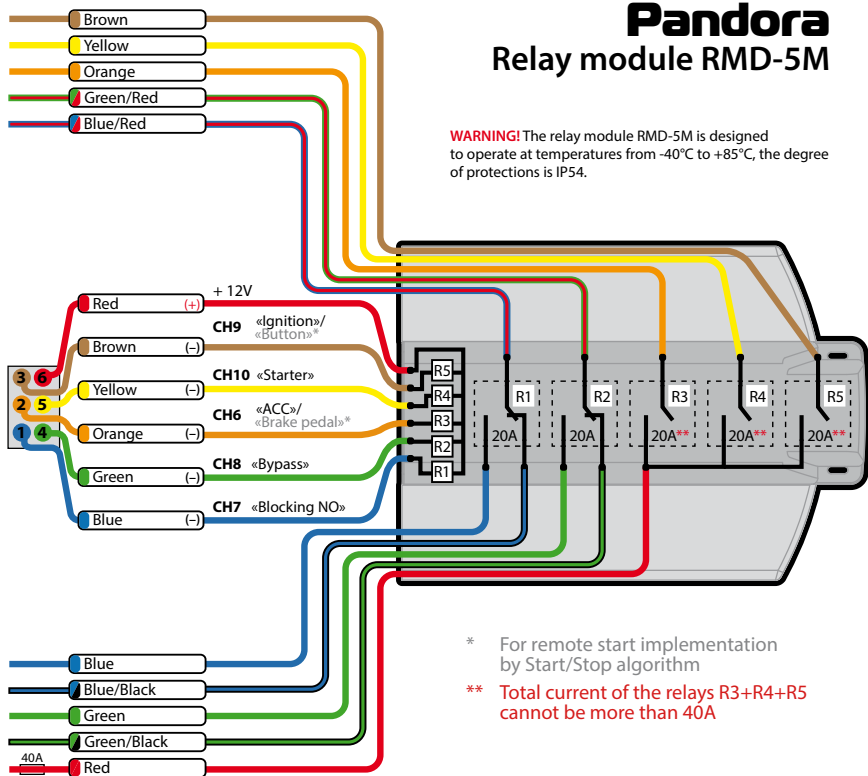

* For remote start implementation by Start/Stop algorithm

** Total current of the relays R3+R4+R5 cannot be more than 40A



shortly press to save



choose mode



shortly press to save



For a prompt remote adjusting of the shock sensor security zones, select «ADJUSTING SHOCK SENSOR WARN LVL» or «ADJUSTING SHOCK SENSOR ALARM LVL» submenu by short presses of **F** button. Sensor sensitivity can be set with short presses of and buttons.

To save new settings of the sensor, press and hold button for 1 second. To exit menu without saving, press and hold **F** button for 1 second.

increase decrease

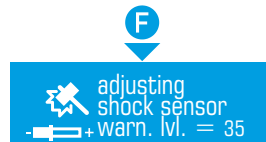

press for 1 second to save

increase decrease



press for 1 second to save

Motion sensor settings

For prompt remote adjusting of motion sensor, select «MOTION SENSOR ADJUSTMENT» submenu by short presses of **F** button. The sensor sensitivity can be set with short presses of and buttons. To save new settings of the sensor, press and hold for 1 second.

To exit menu without saving, press and hold **F** button for 1 second.

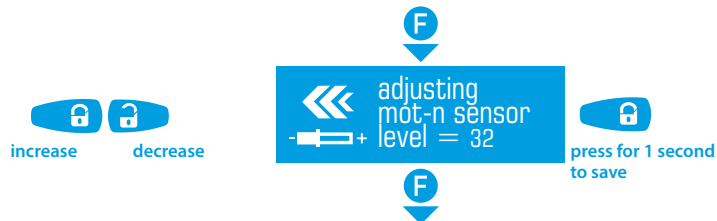

Tilt sensor settings

For prompt remote adjusting of tilt sensor, select «TILT SENSOR ADJUSTMENT» submenu by short presses of **F** button. The sensor sensitivity can be set with short presses of and buttons.

To save new settings of the sensor, press and hold for 1 second.

To exit menu without saving, press and hold **F** button for 1 second.

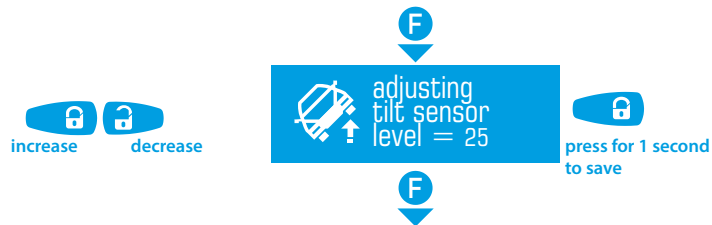

Siren signal settings

To choose the siren signals settings select «SIREN SETTINGS» submenu by short presses of **F** button. Select one of the siren sound options using button. To save new settings shortly press button.

To exit menu without saving, press and hold **F** button for 1 second.



- all sounds signals are enabled



- warning signals are disabled



- alarm and warning signals are disabled

back to the beginning of the settings

Sound notification settings

This function disables all sound signals of the remote control, this mode does not apply to alarm clock and main zones triggering. LED indication and vibration remain enabled.

To set one of two notification options, select «SOUNDS» menu by short presses **F** button. Short press of **🔒** button will disable all sound notifications of the remote control, short press of **🔓** button enables all sound notifications. This mode doesn't require to save.

To exit without saving settings press and hold **F** button for second.



- sound signals are disabled

- sound signals are enabled

Radio channel control settings

There are «Ringtone» and «Alarm» options for the sound notification when the owner is not in the radio coverage zone. To set one of the radio channel control options, select «CONNECTION LOST» menu y short press of **F** button. Select one of the options with short presses of **🔒** button. This menu doesn't require to save.

To exit without saving press and hold **F** for 1 second.



- notification with «Ringtone» sound signal



- notification with «Alarm» sound signal



- sound signals disabled



[back to the beginning of the settings](#)

Service mode

To enable service mode, if additional conditions are met (see the section «Control the system ->Service mode»), press **F** button to select the «VALET MODE» menu and shortly press **🔒** button. To exit the service mode, press **F** button to select the «VALET MODE» menu and shortly press **🔓** button.

To exit the menu without saving the settings, press and hold **F** button for 1 second.



The notification with the «Alarm» sound signal is made once when system is armed. Once a minute short notifications will follow until connection appears or until it will be cancelled by a short press of **F** button.

Time settings

To set the time shortly press **F** button to select the clock menu. Shortly press **🔒** button to set the desired value for hours, and press **🔓** button to set the desired value for minutes. This mode does not require to save.

To exit without saving press and hold **F** button.



hours **🔒** **🔓** minutes

Alarm clock settings

To set up the alarm clock, select «ALARM CLOCK» menu by pressing **F** button. Enable alarm clock with short press of **🔒** button, disable it with short press of **🔓** button.



To set the alarm time, short press **F** button to select the alarm time menu. Shortly press **🔒** button to set the desired value for hours, press **🔓** button to set the desired value for minutes.



hours **🔒** **🔓** minutes

CONTROL THE SYSTEM

Arming

To arm the system when the ignition is off, use one of the methods described below. The system will confirm the command with 1 short sound signal 1x and 1 flash of light signalization 1x .

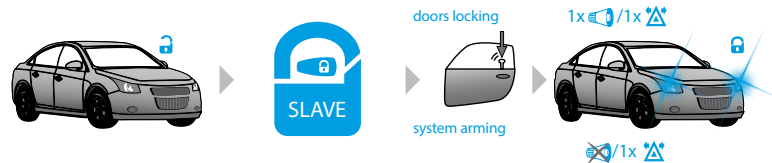

Remote control

Shortly press the **🔒** button on the remote control when you are in the radio coverage zone. The remote control will play «ARMING» ringtone and security mode status icon **🔒** will be changed to **🔓**. To arm the system without a sound notification press and hold the **🔒** button for more than 1 second.

Slave mode



Shortly press the «Lock» button on a factory remote control or use a sensor/button on a door handle (for cars with an intelligent access system).

VALET button

Press and hold the VALET button for 3 seconds. The system will be armed in 30 seconds. The LED indicator is lighting red during the countdown.



! THERE IS AN OPTION IN THE SYSTEM SETTINGS THAT ALLOWS TO ARM THE SYSTEM WITH DISABLED SENSORS (SHOCK/TILT/MOTION AND ADDITIONAL SENSORS).

Disarming

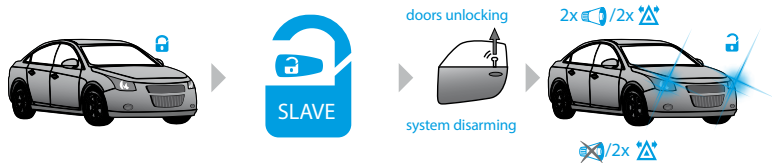
To disarm the system, use one of the methods described below. The system will confirm the command with 2 short sound signals 2x  and 2 flashes of turn indicators 2x .



Remote control

Press and hold the  button on the remote control when you are in the radio coverage zone. The remote control will play «DISARMING» ringtone and security mode status icon  will be changed to .

To disarm the system without sound confirmation press and hold the  button for 1 second or more.

Slave mode

Shortly press the «Unlock» button on a factory remote control or use a sensor/button on a door handle (for cars with an intelligent access system).

VALET button

Enter the «Secret PIN-code» (see the «Emergency disarming using the VALET button» section).

Unlocking the trunk

The system allows to unlock the trunk no matter if the system is armed or not. If the system is armed when this action is performed, the trunk will be disarmed, shock and supplementary sensors will be disabled. All the other security zones will remain armed. If the trunk was not opened in 15 seconds after using «unlock trunk» command, the system will lock it again, enable sensors and arm trunk security zone. This will be indicated with 1 flash of turn signals 1x .

To unlock the trunk choose one of the following methods.

Remote control

When you are in the radio coverage zone, press and hold the  button for 1 second on the remote control until the remote control will play single sound and vibro notification.



Slave mode

Shortly press the open trunk button on a factory remote control or use a sensor/button on a trunk door (for cars with an intelligent access system).

Locking/unlocking doors when ignition is on

The system allows you to lock and unlock doors when ignition is on. To do this, use one of the methods described below.

Remote control

When you are in the radio coverage zone, shortly press  button to lock doors, to unlock doors press  button.

Automatic modes

There are several modes of the automatic door locking:



- When using doors locking mode on switching on the ignition, the doors will be locked automatically 5 seconds after the ignition was switched on.
- When using doors locking mode on car movement start, the system will detect car moving and perform doors locking (it depends on speed status in a digital CAN-bus or motion sensor sensitivity settings).
- Doors will be automatically unlocked when the ignition is switched off.

 THESE MODES ARE DISABLED BY DEFAULT, ALL SETTINGS SHOULD BE MADE BY A QUALIFIED SPECIALIST.

Delayed arming

If when leaving the car you cannot arm it using a remote control (you have your hands full), you can use delayed arming.

Remote control

To activate this mode without sound confirmation, press and hold both  and  buttons for 1 second until the sound and vibration signal.

To cancel delayed arming when it is triggered, simply press  button.

To activate this mode, shortly press  and  buttons simultaneously. The LED indicator will turn red, the system will lock doors and will arm in 30 seconds, the siren will sound 1x  and turn signals will flash once 1x , indicating that the mode is triggered.



Car search function

To easily find your car on a parking, shortly press  button when the car is armed. The system will sound the siren and flash turn signals 5 times in a row.

Remote control

To search for car without sound confirmation, press and hold  button for more than 1 second.

PANIC mode

If your car or you are in danger and you want to draw attention to your car, you can use PANIC mode. In this mode the siren will sound  and turn signals  will flash repeatedly for 30 seconds.

Remote control



To trigger PANIC mode, press  and  buttons simultaneously. To switch it off, press either  or  button.

Remote engine start

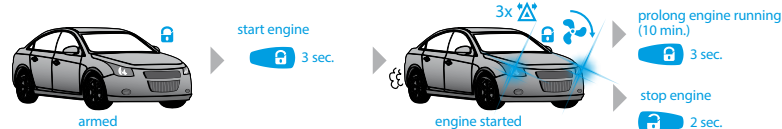
If the system is prepared for remote start, use one of the methods described below to start the engine, the system will confirm the command with 3x  light signalization.





Remote control

- To start the engine, press and hold the  button for 3 seconds (the remote control must be in the radio coverage zone). Sound signal will confirm the command, LCD will show flashing the «engine is running» icon  signifying preparation to the engine start. In a few seconds the engine will be started, the remote will play the «ENGINE START» ringtone and show spinning engine operation icon .

The remote will give notification 1 minute before designated engine stop the  icon will flash and the «ENGINE STOP IN 1 MINUTE» ringtone will play every 10 seconds.

Sending the «REMOTE ENGINE START» command (press and hold the  button for 3 seconds) while the «ENGINE STOP IN 1 MINUTE» ringtone is playing will extend its operation period by 10 minutes. This procedure can be repeated multiple times.

- To stop the engine, press and hold the  button for 2 seconds or more (the remote control must be in the radio coverage zone). The engine will be immediately stopped and it will be confirmed by remote playing the «ENGINE STOP» ringtone and the «Engine is running» icon  will turn off.

Factory key

The system reads digital information from a car, this allows you to start and stop the engine by a factory key:

- To start the engine, press the «LOCK» button 3 times within 5 seconds (the key must be in the radio coverage zone)
- To stop the engine, press the «LOCK» button 3 times within 5 seconds (the key must be in the radio coverage zone).

! REMOTE ENGINE START BY AN ORIGINAL KEY DOESN'T REQUIRED ANY ADDITIONAL SETTINGS. CHECK IF THE FUNCTION AVAILABLE FOR YOUR CAR IN LOADER.PANDORAINFO.COM
THE FUNCTION BECOMES AVAILABLE ONLY 30 SECONDS AFTER ARMING.

«Hold On» mode

This feature allows to leave the car with the engine running for a certain period (15 minutes by default) without keys in the ignition switch. It doesn't depend from the state (armed/disarmed) of the security system, but «Hold On» mode will not be supported without remote start function.



To activate a «Hold On»:

1. Start the engine with the key;
2. Move the shifter to the «Park» position, for cars with automatic transmission, or engage the parking brake for the vehicles with the manual transmission;
3. Press and hold the button at the tag for one second, until first blink of tag's LED. Alarm/remote starter system will activate «Hold On» mode and will hold main vehicle ignition;
4. Switch the ignition off and remove the key from ignition lock cylinder;
5. Close the doors and arm the vehicle from tag/app if necessary. Engine will run for pre-programmed time, then it will shutdown by the end of «Hold On» function.

Engine preheater

Use one of the methods described below for remote start of the engine preheater.

Remote control

To start the engine preheater, select the «ENGINE PREHEATER» menu and shortly press  button, a short press of  button turns off the preheater. If the control of the preheater operation function is implemented, the display will show an icon  for the entire duration of the preheater operation.

Automatic operation of the preheater

The System settings allow to turn on and off the preheater before remote and automatic engine start (except remote start by voltage). Automatic operation of the preheater is possible according to the following parameters: switching on and off according to the engine temperature, operating time.





! THE PREHEATER SWITCHING ON AND OFF BY TEMPERATURE IS ONLY POSSIBLE WHEN THE ENGINE TEMPERATURE SENSOR IS CONNECTED. THIS MODE IS DISABLED BY DEFAULT, ALL SETTINGS SHOULD BE MADE BY A QUALIFIED SPECIALIST.

Service mode

It is recommended to put the system into the service mode before handing it to a car service or valet parking. When this mode is switched on, security system stops interfering with built-in electronics and disables all security, remote and automatic engine start functions for an ease maintenance.

To switch on this mode, disarm the system, turn on the ignition, enter the «Immobiliser PIN-code» (if the «Code immobiliser» function is used) and use one of the methods described below:



Remote control

Press  button to select the «VALET MODE» menu and shortly press  button. To exit the service mode, press  button to select the «VALET MODE» menu and shortly press  button.

Immobiliser buttons

To activate service mode, enter the «Immobiliser PIN-code» and press the immobiliser button 10 times within 20 seconds. To deactivate service mode, turn on the ignition and enter the «Immobiliser PIN-code».

Service mode indication

- Activated Service mode is indicated by: an icon  on the display of the remote control, constant green LED when the ignition is on, long sound signal of a Beeper at the moment you activate the mode.
- Deactivated Service mode is indicated by: no «Service mode» icon  on the display of the remote control, no constant green LED when the ignition is on, two long sound signal of a Beeper at the moment you deactivate the mode.

CONTROL OVER THE SYSTEM IN CASE OF EMERGENCY

The system has emergency ways to deactivate security and anti-hijack functions (using the VALET button and the «Secret PIN-code») in case of loss or failure of control devices or in case of discharge of a battery (when you cannot replace it or charge).

- «Secret PIN-code» is located under protective layer on the «Owner's individual card»
- VALET button is located on the external VALET button or on the main unit.

! BEFORE USING EMERGENCY SYSTEM CONTROL, CHECK THE SYSTEM AND VEHICLE CONTROL DEVICES: CHECK A BATTERY, TURN ON A DEVICE IN ACCORDANCE WITH ITS MANUAL (IF REQUIRED).

IF ALL DEVICES ARE WORKING, TRY TO MAKE A PRIMARY VEHICLE DIAGNOSIS: CHECK THE VEHICLE CONTROL DEVICES, VEHICLE BATTERY CHARGE LEVEL, GEARBOX SELECTOR POSITION, CHECK INFORMATION ON THE DASHBOARD.

! REMOVE THE PROTECTIVE LAYER CAREFULLY. DO NOT USE ANY SHARP OBJECTS TO AVOID DAMAGING OF HIDDEN INFORMATION UNDER THE PROTECTIVE LAYER.

! THE EXTERNAL VALET BUTTON IS PLACED IN THE INTERIOR (CHECK «SYSTEM MODULES LAYOUT»)

Owner's personal card

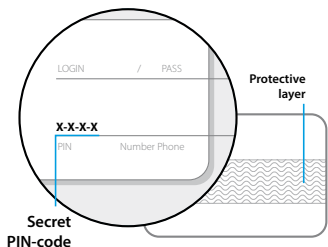

External VALET button

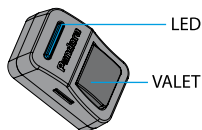

READ THE PROCEDURE FOR ENTERING THE PIN-CODE BEFORE USING EMERGENCY FUNCTIONS.

- **Enter the first digit** • Press the button the number of times equal to the first digit. Pauses between presses should not exceed 1 second. Each pressing will be confirmed with an orange LED indicator flash. Wait for more than 1 second, a red flash of LED indicator and a short single sound of the Beeper will confirm the input of the first digit. Then you can enter the next digit.

- **Enter the second digit** • Press the button the number of times equal to the second digit. Pauses between presses should not exceed 1 second. Each pressing will be confirmed with an orange LED indicator flash. Wait for more than 1 second, a red flash of LED indicator and a short single sound of the Beeper will confirm the input of the second digit. Then you can enter the next digit.
- **Enter the third digit** • Press the button the number of times equal to the third digit. Pauses between presses should not exceed 1 second. Each pressing will be confirmed with an orange LED indicator flash. Wait for more than 1 second, a red flash of LED indicator and a short single sound of the Beeper will confirm the input of the third digit. Then you can enter the next digit.
- **Enter the fourth digit** • Press the button the number of times equal to the fourth digit. Pauses between presses should not exceed 1 second. Each pressing will be confirmed with an orange LED indicator flash. The correct input will be confirmed with the series of green and red flashes of the LED indicator.

Emergency disarming / Beach mode disabling

In case you cannot disarm the system as usual, use the VALET button and the «Secret PIN-code» written on the Owner's personal card (see the «General information» section):

If your car is locked, unlock it by a factory key. Not paying attention to the siren signals, make sure that the ignition is off and enter the «Secret PIN-code» (see the procedure description above). If there are no siren sounds or LED flashes, check the battery. It is not possible to enter the «Secret PIN-code», if there is no power supply.

- The system will be disarmed in case of correct PIN-code input. It will be confirmed with the series of green and red flashes of the LED indicator, the series of sound signals of the Beeper, 4 beeps of the Siren and 4 signals of the light signalization.
- Emergency disarming is equivalent to a normal method of disarming. No additional actions are required for further operation of the system.
- The system will stay in previous state in case of incorrect input of the PIN-code. It will be indicated with a long red flash of the LED indicator. New input can be attempted after 5 seconds.

Emergency control of the code immobiliser

This section describes how to deactivate and activate code immobiliser, which uses standard car controls (buttons, levers, pedals) to enter the Immobiliser PIN-code.

Emergency deactivation of the code immobiliser

To temporarily deactivate the code immobiliser function (pin-to-drive), turn on the ignition when the system is disarmed. Enter the «Secret code» from the owner's personal card using the VALET button. The immobiliser functions will be being deactivated until the ignition is turned off.

Emergency control of the code immobiliser mode

This method is used for a permanent deactivation of the code immobiliser function (pin-to-drive). Deactivation and activation is made by entering the «Secret code» from the owner's personal card using the VALET button while system is disarmed, ignition is off and the service mode is disabled.

1. Enter the programming mode by entering the «Secret PIN-code» (from the Owner's personal card) or the «Service PIN-code» (factory preset is 1-1-1-1). The PIN-code should be entered using the external or located on the base unit VALET button.
2. Enter the programming level №13 - press the VALET button 13 times (without pauses).
 - **TO DEACTIVATE THE FUNCTION** – The LED indicator will be green after entering the programming level. The system will wait 10 seconds for entering the «Secret PIN-code». If the PIN-code is not entered within 10 seconds or the input is incorrect, the siren will sound one signal, the LED will produce the series of red and green flashes and the system will return to the programming menu. Enter the «Secret PIN-code» that is written on the owner's plastic card. The system will confirm deactivating with two sound signals of the siren, a long red LED flash and two sound signals of the siren. Turn on the ignition and then turn off to exit programming mode. The function will be deactivated.
 - **TO ACTIVATE THE FUNCTION** - The LED indicator will light red and the Beeper will sound a long beep after entering the programming level. The system will wait for action. Press the VALET button once activate the immobiliser function. The system will confirm enabling with one short sound signal of the Siren/Beeper and a green LED light. Turn on the ignition and then turn off to exit programming mode. The function will be activated.

PROGRAMMING THE SYSTEM

System settings and parameters can be configured using the Pandora Alarm Studio program and the Pandora Specialist application. Some functions can be configured only by the programming menu of the system. It is required to put the system to programming mode to get access to the settings

Entering/Exiting programming mode

You can enter the programming mode only if the base unit is powered from a USB cable or the main power supply is connected, the ignition is off, the system is disarmed and service mode is off. To enter programming mode, enter the «Service PIN-code» (default value is 1-1-1-1) using an external VALET button or the VALET button located on the base unit.

! SEE THE DETAILED DESCRIPTION OF PIN-CODE ENTERING PROCEDURE IN THE «CONTROL OVER THE SYSTEM IN CASE OF EMERGENCY» SECTION OF THE USER MANUAL.

! IF YOU DON'T HAVE THE 'SERVICE PIN-CODE', YOU CAN ENTER PROGRAMMING MODE USING THE 'SECRET PIN-CODE' WRITTEN ON THE OWNER'S CARD.

IT IS FORBIDDEN TO DAMAGE THE PROTECTIVE LAYER OF THE «OWNER'S PERSONAL CARD» - THE INFORMATION UNDER THE PROTECTIVE LAYER OF THE CARD IS INTENDED ONLY FOR THE OWNER OF THE SYSTEM. WHEN THE OWNER COMPLAINS ABOUT THE ERASED PROTECTIVE LAYER, THE SYSTEM IS REINSTALLED AT THE EXPENSE OF THE INSTALLER.

The system stops to execute commands when it is in programming mode. Therefore, exit programming mode after changing settings and parameters of the system.

To exit programming mode, use one of the following methods:

- Press and hold the VALET button for more than 10 seconds;
- Turn on and then turn off the ignition when a USB cable is disconnected and the main power supply of the system is connected;
- Disconnect the power supply (main and USB power supply). The system will reboot programmatically (all changes will be saved) after exiting programming mode. All ways to exit programming mode are accompanied by sound signals of the siren and light signals of the LED indicator. The light signals indicate the number of paired control devices.

Pandora Alarm Studio

The Pandora Alarm Studio allows you to change the main settings and parameters of the system, update firmware, download installation manuals, connect to the server to make CLONE procedure. A current version of the Pandora Alarm Studio can be downloaded from pandorainfo.com. The Pandora Alarm Studio is provided only to authorized installers of Pandora systems.

- Download the Pandora AlarmStudio to a PC with Windows XP/Vista/7/8/10.
- Run the Pandora AlarmStudio;
- Connect the system to the PC via a USB cable;
- Put the system to the programming mode;
- The Pandora AlarmStudio will automatically connect to the system and you will be able to configure settings and update firmware.

Updating firmware

It is recommended to update firmware of the base unit before installing and programming the system. You can update firmware using the Alarm Studio application after entering programming mode or using quick boot algorithm (the PIN-code is not required).

Quick boot mode: open the Alarm Studio; de-energize and disconnect the system; press and hold the VALET button located on the base unit; release the button immediately after connecting the system to a computer via USB cable; the system will enter boot mode.

! IF THE BOOT MODE HAS BEEN INTERRUPTED FOR SOME REASON AND THE STATUS INDICATOR LIGHTS RED, YOU NEED TO LOAD FIRMWARE USING QUICK BOOT MODE (WITHOUT ENTERING THE PIN-CODE).

Pandora Specialist application

The Pandora Specialist mobile application (Android only) is available for system configuration:

- Download and install the Pandora Specialist mobile app (scan the QR-code or go to the Google Play app store);
- Connect the USB-OTG adapter to your smartphone or tablet;
- Connect the USB cable to the system;
- Connect the USB-OTG adapter to the USB cable;
- Enter the «Service PIN».



Programming using the VALET button

The system allows programming some settings using the VALET button. To configure all settings use Pandora Alarm Studio program and Pandora Specialist application.

Enter the programming mode by entering the «Service PIN-code», use the VALET button to enter the desired level number (press the button a number of times, equals to the level number; pauses between presses should not exceed 1 second). The system will confirm correct input with red LED flashes and short sound signals of a siren and proceed to the desired level. If the input was incorrect, the system will not confirm input and will wait a new level input after a series of green and red flashes.

For quick access to the higher level, press and hold the VALET button. The siren will sounds tone beeps (up to 10). These sounds means the sequence number of a two-digit level number (the first signal – level №10, the third signal – level №30, the tenth signal – exit programming menu). Release the VALET

button immediately after the desired number of signal. To enter an intermediate level, press the VALET button the number of times equals to the second digit of the desired level number immediately after releasing the button. The system will confirm correct input with red LED flashes and short sound signals of the siren/beeper and proceed to the desired level.



PROGRAMMING TABLE	
Level 1	Recording remote controls (D-010, DXL-707/078/077, R-387) 4 pcs.
Level 2	Changing the factory preset of the «Service PIN-code»
Level 3	Recording the idle speed to the system memory
Level 4	Resetting to factory settings
Level 11	Programming and configuring the «Immobiliser code»
Level 12	Fuel level calibration
Level 13	Emergency control of the code immobiliser
Level 17	Programming bypass of original immobiliser
Level 30	Programming the «Beach mode PIN-code»

Level 1 – Recording remote controls

Prepare to record all remote controls (you can record up to 4 remote controls), install batteries in the remote controls. If the remote controls are off, switch them on in accordance with the manual.

Enter programming menu and then press the VALET button once. The LED indicator will light green and the system will enter the remote controls recording mode. Remote controls are recorded (paired) one by one, in any order and without time limit. All previously recorded remote controls will be removed when you overwrite new remote controls or record old remote controls again.

Recording remote controls:

Press three buttons    simultaneously and hold them for 1 second (until a short beep from the main remote control or until LED fading of an additional remote), then release the buttons. If recording was successful, the remote will emit 2 short beeps and the base unit will emit 1 beep, after that you can move to recording the next remote control.

Saving changes:

To finish recording, press the VALET button once. The series of red and green flashes of the status LED indicator will confirm saving.

Level 2 – Changing the factory preset of the «Service PIN-code»

Prepare a new value of the «Service PIN-code», it should consist of 4 digits (from 1 to 9). Write down or remember the new PIN-code. Enter programming menu and then press VALET button twice. The system will enter «Changing Service PIN-code» mode and the status LED indicator will turn off.

Changing the «Service PIN-code»:

- Enter the first digit of the code using the VALET button. Press the button a number of times, equals to the first digit. Pauses between presses should not exceed 1 second, every pressing will confirm with an orange LED indicator flash. Pause for more than 1 second and a red LED indicator flash confirms the input of the first digit. Then you can enter the next digit;
- Enter all four digits again.
- If you were able to correctly enter the «Service PIN-code» twice, the indicator will produce the series of red and green flashes, new PIN-code will be recorded, the system will return to programming mode. In case of the incorrect code input the indicator will be lit red, the system will return to programming mode.

Level 3 – Recording the idle speed to the system memory

To timely turn off the starter during automatic or remote engine start via digital or analog tachometer input and the correct operation of the «Smart Turbo Timer», it is necessary to record the engine idle speed.

To record the idle speed to the non-volatile system memory, enter the programming menu. Press the VALET button three times. Switch on the ignition and start the engine after entering this level of programming (the engine should be warmed-up, idle speed should match the stable idle speed of the warmed-up engine). The system will confirm the presence of the idle speed status with green flashes of the LED indicator. Wait until the stable idle speed will be reached and save the changes. Saving changes:

Press the VALET button once to save idle speed. Successful recording of the idle speed will be confirmed with the series of red and green flashes of the LED indicator. The system will exit programming menu and reboot after saving the idle speed.

Level 4 – Resetting to factory settings

The procedure recovers the factory settings of the system without deleting previously registered devices (tags, mobile device, relays, etc.) that are stored in the non-volatile memory.

To reset the settings enter the programming mode and press the VALET button four times. Press and hold the VALET button for more than 4 seconds until a siren sound, then release the button. The system will confirm the resetting to the factory settings with a long red flash of the LED indicator. After that the system will return to a programming mode.

Level 11/30 – Programming the «Immobiliser code» / «Beach mode PIN-code»

• **To program the «Immobiliser code»**, enter the programming mode and press the VALET button 11 times to enter level №11, to program «Beach mode PIN-code» enter level №30. After entering the level system will wait for buttons pressing. Each pressing will be confirmed with an orange flash of the LED. You can turn on the ignition (the system will stay in programming mode). Some buttons can be detected via digital bus only when ignition is on. The system can determine buttons via analog «Code immobiliser» inputs or via digital protocol of a car (check the «Code immobiliser» options on loader. pandorainfo.com, Pandora Alarm Studio, Pandora Specialist). After selecting active buttons, press the VALET button to enter the next sublevel (Entering the PIN-code).

• Entering the PIN-code:

Program the immobiliser deactivation PIN-code using the selected button or buttons on this sublevel. The code can consist of one or more memory cells, each memory cell can store a sequence of pressing each of the five selected immobiliser buttons. The code is entered by pressing the selected buttons for at least 1 second. Each pressing is confirmed with an orange flash of the LED. A pause for more than 1 second and the red LED confirms the input for the current memory cell, you can start entering the next memory cell. After entering the code, press the VALET button to enter the next sublevel.

• Confirmation of the PIN-code input

Confirm the entered PIN-code on this sublevel. Repeat the procedure described above and press the VALET button. The system will compare two inputs after that.

- If you correctly enter the code twice, the indicator will produce the series of red and green flashes and the Beeper will produce the series of sounds, the new code will be recorded, the system will return to the programming level №0.

- In case of the incorrect code input the indicator will be lit red and the Beeper will sound a long beep, the system will not change the code and will return to the programming level №0.

Level 12 Fuel level calibration

! THIS PROCEDURE IS USED ONLY IN CASE OF ANALOG CONNECTION. AT LEAST 2 VALUES ARE REQUIRED FOR CORRECT DISPLAY OF FUEL LEVEL. IN SOME CASES FUEL LEVEL CALIBRATION SHOULD BE PERFORMED BY ALL SPECIFIED POINTS (FOR MORE EXACT DEFINITION).

To control fuel level, make connection and configure the settings:

Setting is performed via the Pandora Alarm Studio /Pandora Specialist Application». The «Use INP to control fuel level» item should be enabled in the settings, the default setting of this input (input settings) must be unselected. Make a connection in accordance with the «Fuel control input» scheme.

Fuel level calibration

- Select the desired sub-level corresponding to the current fuel level. The total number of sublevels are 12 (listed in the table). Enter the programming level 12. The LED indicator will be red and the system will enter to the sublevel 12-0 (0%). Enter the number of the desired sublevel (10-100%) by pressing the VALET button (press the button a number of times equals to a digit; pauses between presses should not exceed 1 second).
- Start the engine for at least 1 minute, then press VALET button – the data will be sent to the base unit. Press «Arming» button of the remote to save the setting. If you want to cancel the current setting, press the «Disarming» button of the remote.
- To exit the programming mode, enter sublevel 12 or press VALET button more than 12 times.
- Repeat the procedure for the second and next calibration points.

Reset all calibration values

To reset all calibration values, proceed to the sublevel 11 (do not switch on the ignition). Reset confirmation is performed by pressing «Arming» button of the remote, exit without confirmation and exit the menu are performed by pressing the VALET button.

Sublevel	Fuel level
12-0	0%
12-1	10%
12-2	20%
12-3	30%
12-4	40%
12-5	50%
12-6	60%
12-7	70%
12-8	80%
12-9	90%
12-10	100%
12-11	Reset all calibration values
12-12	Exit the programming mode

Level 13 - Emergency control of the code immobiliser

! THE DETAILED INFORMATION IS AVAILABLE IN «EMERGENCY CONTROL OF THE SYSTEM» SECTION

Level 17 – Programming bypass of the vehicle immobiliser system

Bypass learning procedure is performed on this level.

! THE DETAILED INFORMATION CAN BE FOUND IN INSTALLATION SCHEMES FOR A CAR ON THE LOADER.PANDORAINFO.COM, PANDORAALARM.STUDIO, PANDORA.SPECIALIST.

ADDITIONAL DEVICES

Remote control R-387

One-way remote control for controlling the security system

CONTROL COMMANDS

Arming/Disarming | Trunk | Remote engine start

868MHZ RADIO INTERFACE | THREE CONTROL BUTTONS | LED INDICATOR | CR-2032 BATTERY



WARRANTY OBLIGATIONS

Manufacturer guarantees correct operation of the service-security system if exploitation, installation, storage and transportation conditions described in this manual were met.

The system should only be used according to installation scheme and user manuals.

The system is meant to be installed by the professional car electronics installers. The installer should fill in installation certificate that is included in this manual.

Parts malfunctioning during warranty period on the fault of the manufacturer should be repaired or replaced by the installation center of the manufacturer or by certified service center. List of certified service centers can be found on pandorainfo.com

The user loses the right for warranty services in the following cases:

- when warranty period expires;
- if exploitation, installation, storage or transportation conditions were not met;
- if there is mechanical damage of the external parts of the system after it is sold.

This includes: fire damage, consequential damage in case of car accident, aggressive liquids and water seeping damage, damage caused by improper use;

- if the damage was caused with incorrect settings and parameter adjustment;
- if system devices are replaced with any devices that are not recommended by the manufacturer;
- if manufacturer sealing is broken;
- if there is no properly filled warranty card and installation certificate.

Warranty period is 3 years since the moment of purchase, but no more than 3.5 (three and a half) years since the moment of production. This warranty does not include batteries of the remotes, as they have their own service lifetime.

Maintenances and repairs of the system with expired warranty period are carried out at the expense of the user on a separate contract between the user and the installer/service center.

! WE RECOMMEND THAT YOU ASK AN INSTALLER TO FILL OUT THE INSTALLATION CERTIFICATE AND THE WARRANTY CARD. THESE DOCUMENTS MAY BE REQUIRED FOR CONTACTING THE CUSTOMER SUPPORT.

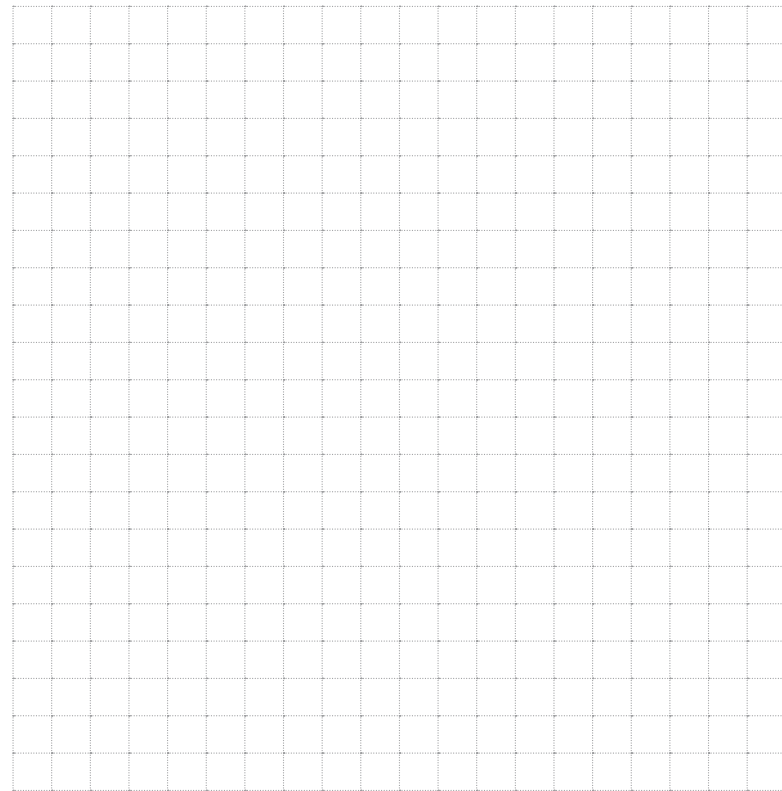
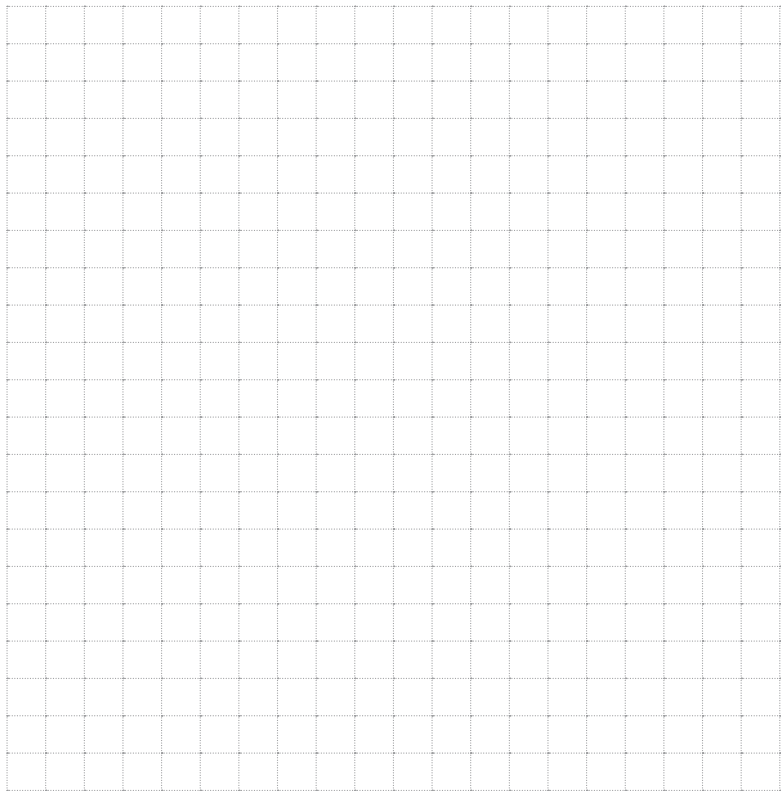

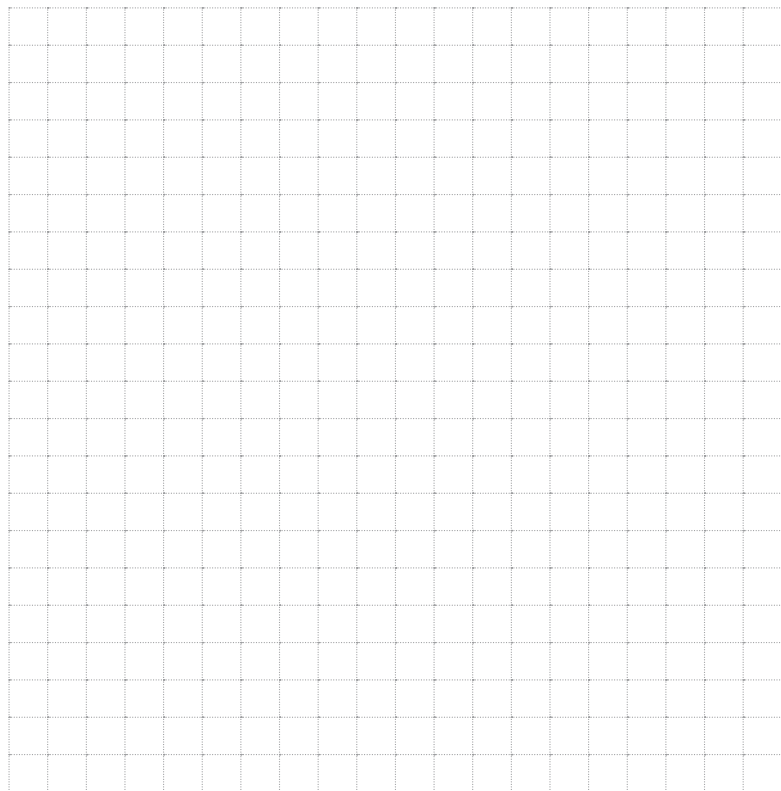

Installation certificate

I, the undersigned _____
Position, name

professional installer, certify that installation of the service-security system, specified below, was carried out by me in accordance with manuals and schemes provided by the manufacturer.

Car specifications:

Car model _____

Type _____

Id number (VIN) _____

Registration number _____

Security system specification:

Model Pandora Light v3

Serial number _____

Service center name, full address and installer's stamp _____

Signature _____ / _____ /
Signatory

Work accepted _____ / _____ /
Signatory

Date « ____ » _____ 20 ____ y.

Acceptance certificate

Model **Pandora Light v3** is in conformity with Electromagnetic Compatibility Directive EMC 2004/108/EC and R&TTE Directive 1999/5/EC.

Serial number _____ Date of production _____

Responsible person's signature (stamp)

Packager _____

Signature (personal stamp)

Warranty card

Model **Pandora Light v3**

Serial number _____

Date of purchase « ____ » _____ 20__ year

Seller's (installer's) stamp

Seller's signature _____