

## Pandora would like to thank you for choosing our service-security system

**Pandora Light** – is a car service-security system built for cars with on-board voltage of 12V. It is a complex engineering solution, which includes unique and modern technological software and hardware solutions.

When building the **Pandora Light** we were using the most up-to-date electronics from world's best manufacturers. The device is built using high-precision mounting and control machinery, thus we guarantee highest possible quality, reliability and stable technical characteristics for the whole operation period.

**Pandora Light** has a cryptographically strong authorization code with unique dialog algorithm and individual 128 bit encryption key on every device. We guarantee 100% protection from electronic hacking for the whole operation period.

The system is built for your convenience: it's ergonomic, reliable, has the highest security and service characteristics, 3 years unconditional warranty and free service and support on the territory of Russian Federation and nearest states. We are happy to provide any support we can – feel free to use our online support.



**WARNING! It is strongly advised to have professional car mechanic installing the system. Any car electronics installer should be able to install Pandora Light using installation scheme in this manual and Alarm Studio software. Most features are highly dependent on competent installation. Our systems are thoroughly tested for quality, so if a feature fails to produce expected result, most likely the problem is in improper installation.**

This device has limited external factors resistance. It should not be subjected to water beyond occasional splatter, or operated in temperatures outside -40 to +80° C range. All system components must be installed only in a car interior.

**Our web site: [www.pandorainfo.com](http://www.pandorainfo.com)**  
**Customer support: [support@pandorainfo.com](mailto:support@pandorainfo.com)**



Product is in conformity with Electromagnetic Compatibility  
Directive EMC 2004/108/EC and R&TTE Directive 1999/5/EC

## Table of contents

<b>System features</b>	<b>4</b>
Remote control	4
Base unit	4
Security zones	5
<b>System set</b>	<b>5</b>
<b>Remote control</b>	<b>6</b>
LED indicator signals	6
Quick access functions of the remote control	7
Icons of the remote control	9
Arming procedure	10
Disarming procedure	10
Unlocking a trunk	11
Locking/unlocking doors when ignition is on	11
Car search function	12
Delayed arming	12
Panic mode	13
Remote and automatic engine start	13
Program neutral procedure (reservation mode)	14
Remote engine start	15
<b>Code immobilizer function (pin-to-drive)</b>	<b>16</b>
<b>System settings menu</b>	<b>16</b>
Engine heater	18
Time channels	18
Check car status	20
Event history	20
Automatic engine start	22
<b>Wires description</b>	<b>24</b>
<b>Wiring diagram and connectors pin-out</b>	<b>26</b>

<b>Sensor settings</b>	<b>30</b>
Shock sensor settings	30
Motion sensor settings	32
Tilt sensor settings	32
Siren signal settings	33
Sound notification settings	33
Radio channel control settings	34
Service/Valet mode	35
Time settings	35
Alarm clock settings	36
Replacing a battery in the remote control	36
<b>Control over the system in case of emergency</b>	<b>37</b>
<b>Programming the system</b>	<b>39</b>
Entering the programming mode	39
Exiting the programming mode	39
Preparing to program the system using a computer	40
Updating firmware	40
Programming using the VALET button	40
<b>Additional information</b>	<b>46</b>
Siren sound and light signalization	46
Meaning of the LED indicator signals	46
Checking the number of recorded remote controls	47
System modules layout	48
Warranty obligations	49
Installation certificate	50
Acceptance certificate	51
Warranty card	51

## SYSTEM FEATURES

### Remote control

- Separate buttons for arming and disarming.
- 14 independent security zones control.
- Vibrating alert.
- 16 notifications ringtones.
- LED lighting of the LCD.
- Vibration confirmation of the button presses.
- AAA battery (1,5 V).
- Battery level indicator.
- Current time indication.
- Time synchronization with the base unit for exact time stamp in the event history.
- Engine and interior temperature, car battery voltage, fuel level indication.
- Prompt remote adjustment of the shock, motion, tilt sensors sensitivity.
- Event history with time and event stamps.
- Automatic control of RF coverage zone.

### Base unit

- Individual PIN-code for disarming
- Dialog coding of control commands sent at a frequency of 868 MHz.
- Individual 128-bit encryption key.
- Event history with exact time stamps is stored in the base unit and is transferred to the remote when it is in the range.
- Monitoring of on-board voltage.
- Built-in integral accelerometer for determining motion and shocks with adaptive processing algorithm and sensitivity controls via the remote.
- Separate inputs for hood and trunk sensors..
- Advanced processing of sensor data, eliminating false alarm possibilities.
- Built-in temperature sensor, additional engine temperature sensor.
- Sequential unlocking of the doors.
- Arming when the engine is running.
- Automatic arming.
- Can be complemented with BM-103/105 single-wire digital block relay.
- Software updates via built-in micro-USB socket.

## Car security zones

Pandora Light service-security system guards following independent zones with corresponding zone notifications on the remote and recording alarms into the event history:

- doors
- front hood
- trunk
- ignition
- brake pedal
- triggering of the shock sensor (warning level)
- triggering of the shock sensor (alarm level)
- triggering of the motion sensor
- triggering of the tilt sensor
- critically low in-board voltage
- OE car alarm status (via CAN-bus)
- triggering of the additional sensor (warning level)
- triggering of the additional sensor (alarm level)

## SYSTEM SET

1.	Base unit	1
2.	Remote control	1
3.	External VALET button	1
4.	User manual	1
5.	Owner's plastic card	1
6.	Main cable of the base unit	1
7.	LIN-interface cable	1
8.	IMMO-KEY-interface cable	1
9.	Fastening kit	1
10.	Relay module	1
11.	Packaging	1



**ATTENTION!** The manufacturer reserves the right to change the system set and construction of the product to improve its technological and operational parameters without notification.

## REMOTE CONTROL

Two-way remote is the main mean of control over the system.

For easily distinguishable notifications the remote uses 16 ringtones. Each ringtone matches particular event. Remote has flashing LED indicators for additional information.



**ATTENTION!** All control commands are transmitted via radio channel, for maximum effectiveness and range it is recommended not to shield aerial area (see picture) with fingers when using a remote control.

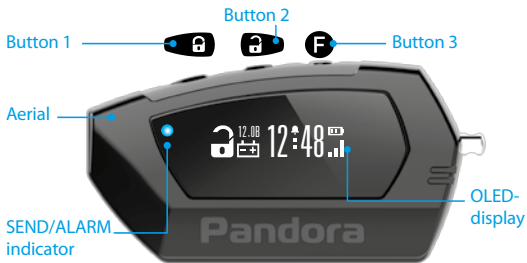

## LED indicator signals

### Green indicator:

- Flashes if there is a connection with the base unit
- Goes dark when there is no connection with the base unit.









### Red indicator:









- Flashes frequently if there is any notification
- Flashes occasionally when there is no connection



**ATTENTION!** A remote control is a unified control device. Its functions depend on security system model.

## Quick access functions of the remote control

	System is disarmed		System is armed (no alarm events)
	Ignition is switched on	Ignition is switched off	
 (short press)	Lock doors without arming	Arming with sound confirmation	Search mode – flashes of turn signals with sound signals for 5 seconds
 (1 sec.)		Arming without sound confirmation	Search mode – flashes of turn signals without sound signals for 5 seconds
 (2 sec.)	Switch on «Ignition maintenance» mode		
 (3 sec.)	Switch on «Programmed neutral»		Remote engine start
 (short press)	Unlock doors	Unlock doors	Disarming with sound confirmation
 (1 sec.)		Unlock doors	Disarming without sound confirmation
 (> 2 sec)	Switch off «Ignition maintenance» mode		Switch off the ignition during remote or automatic engine start procedure.
 (short press)	Switch on LCD lighting (available only on the remote with LCD)		

 (1 sec.)	Unlock trunk (CH1)		
 (2 sec.)	Switch on/off timer channel (CH2)		
 (3 sec.)	Switch on/off remote (available only on the remote with LCD)		
 +  (short press)	PANIC mode		
 +  (short press)	Arming when the engine is running with sound confirmation	Arming in 30 seconds With sound notification	
 +  (1 sec.)	Arming when the engine is running with sound confirmation	Arming in 30 seconds without sound notification	



## Icons of the remote control

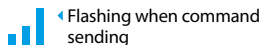

◀ Flashing when command sending



◀ Security mode status



◀ Remote control battery level

12:48

◀ Numeric indicator displays current time



◀ Battery voltage



◀ Interior temperature



◀ Engine temperature\*



◀ Fuel level\*



◀ Alarm clock



◀ Shock sensor security zone



◀ Warning level of the sensor;

◀ Alarm level of the sensor



◀ Tilt sensor  
Security zone



◀ Motion sensor security zone



◀ Doors security zone



◀ Front hood security zone



◀ Trunk Security zone



◀ Ignition Security zone



◀ Handbrake/ neutral indicator,  
Brake pedal security zone



◀ Low voltage security zone



◀ Engine operation icon



◀ Engine is stopped



STOP

---

\* Separate display indication of doors, original alarm status, fuel level depend on information in CAN-bus digital protocol of specific car

## Arming procedure

Arming the system allows monitoring of all security zones, locks the doors and blocks the engine.

To arm the system when the engine is stopped, shortly press  button on the remote control. The siren will emit one sound signal and turn signals will flash once. The remote control will play "ARMING" ringtone and security mode status icon (the lock) will change to .

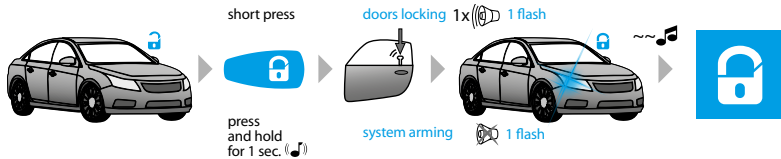



For arming without sound confirmation press  for more than 1 second.

If when arming doors, hood or trunk were open, the siren will sound 4 short signals instead of 1, turn signals will flash 4 times, remote will play "WARNING!" ringtone (after "ARMING" ringtone) and will show troubled zone. This zone sensor will be disabled at that moment. Sensor will be armed again in 15 seconds after the zone was set right.

For emergency arming when ignition is switched off, press and hold the VALET button for 3 seconds until the system confirms with red LED indicator flash. A car will be armed in 30 seconds.

## Disarming procedure

To disarm the system, shortly press  button on the remote control. You will hear 2 short siren sounds and will see 2 flashes of turn signals. The remote will play "DISARMING" ringtone and security mode status icon will change to: .

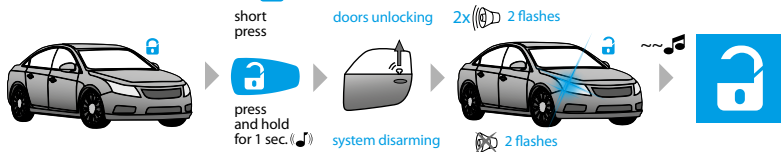

For disarming without sound confirmation press  button for more than 1 second.

If there were new alarming events during the time system was armed, siren will sound 4 times and turn signals will flash 4 times, the remote control will sound "WARNING!" ringtone (after "DISARMING" ringtone) and will indicate zones triggered. All recent alarm events can be viewed in the event history.

## Unlocking a trunk

To independently unlock the trunk, no matter if the system is armed or not, press **F** button and hold it for 1 second.



If the system is armed when this action is performed, the trunk will be disarmed, shock and supplementary sensors will be disabled. All the other security zones will remain armed.

If the trunk was not opened in 15 seconds after using «unlock trunk» command, the system will lock it again, enable sensors and arm trunk security zone. This will be indicated with 1 flash of turn signals.

## Locking/unlocking doors when ignition is on

The system controls doors locking when the ignition is on. Shortly press **lock** button to lock doors. Shortly press **unlock** button to unlock doors.

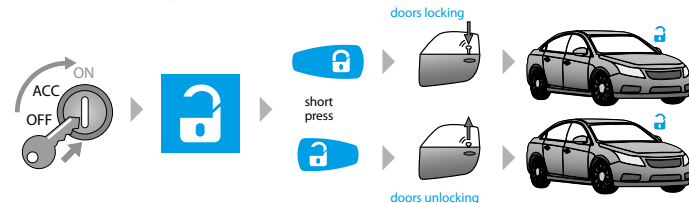

There is an automatic movement lock mode that will lock the doors at the car movement or on switching on the ignition. Doors will be unlocked after the ignition is switched off. There is an option

in the settings that allows to prohibit automatic unlocking on switching off the ignition.

When using doors locking mode on the car movement start, the system will detect car moving and perform doors locking (it depends on motion sensor sensitivity settings).

When using doors locking mode when switching on the ignition, in no less than 5 seconds after the ignition was switched on, the doors will be locked automatically. If any door was opened after the ignition had been switched on, automatic locking will be disabled to prevent locking the keys inside the car.

## Car search function

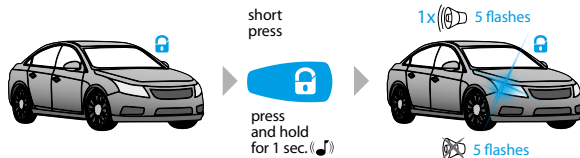

To easily find your car on a massive parking, shortly press  button when the car is armed. The system will sound the siren and flash turn signals 5 times in a row.





To search for car without sound confirmation, press and hold  button for more than 1 second.

## Delayed arming

If when leaving the car you cannot arm it using a remote control (you have your hands full), you can use delayed arming.

To activate this mode, shortly press  and  buttons simultaneously. The LED indicator will turn red, the system will lock doors and will arm in 30 seconds, the siren will sound and turn signals will flash once, indicating that the mode is triggered.

To activate this mode without sound confirmation, press and hold both  and  buttons for 1 second until the sound and vibration signal.

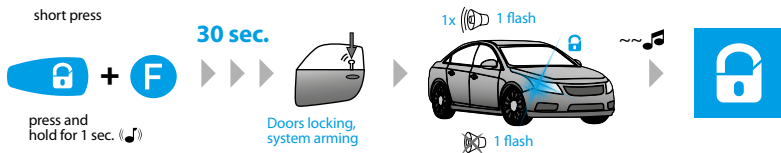

To cancel delayed arming when it is triggered, simply press button.

## Panic mode

If your car or you are in danger and you want to draw attention to your car, you can use PANIC mode. In this mode the siren will sound and turn signals will flash repeatedly for 30 seconds. To trigger PANIC mode, press and buttons simultaneously. To switch it off, press either or .



## Remote and automatic engine start

The system allows for remote engine start using remote engine start command or automatic engine start using preconfigured automatic engine start function. Remote start can be used to heat engine and interior, charge battery or to cool the interior with air conditioning.

Remote and automatic start can only be used when the system is armed. If the car has manual transmission, remote or automatic start will only occur if the program neutral procedure (reservation mode) was followed when the car was arming. Remote and automatic engine start on automatic transmission cars will only occur, if transmission selector lever was left in the "P" position.





When using remote and automatic engine start functions, make sure that the car is secured with handbrake or some other means of fixing the car on a parking position.

While system is in remote and automatic start mode, it keeps performing all security functions of all of the security zones excluding shock sensor. To compensate, motion sensor sensitivity and

responsiveness will be increased. If any security zone will be triggered, the engine will be immediately stopped and alarm mode will be entered. Herewith all engine blocking functions will be activated.



### Program neutral procedure (reservation mode) (for cars with manual transmission)

If you are planning to use remote and automatic engine start on cars with manual transmission, before arming you will need to perform following actions:

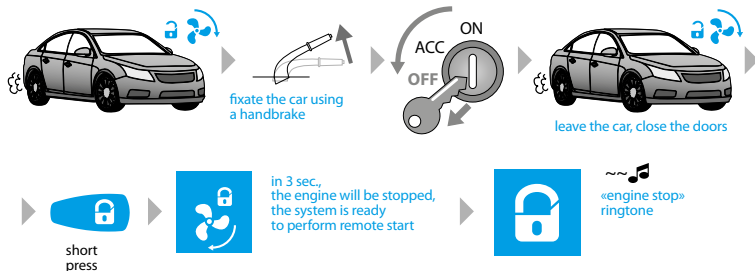
1. While ignition is on and engine is running, fixate the car with the handbrake and put the gear lever to the neutral position. Program neutral procedure will be switched on automatically (it depends on the system settings) or press and hold  button for 3 seconds to forced switch on this program.
2. Turn the key in the ignition lock to the OFF position (the engine should still be running) and take it out of the lock.
3. Leave the car, close the doors.
4. Press  button to arm the car and lock the doors. The engine operation icon  will be spinning on LCD remote and security mode status icon  will be shown.
5. The engine will be stopped. Now the system is ready to perform remote and automatic engine start.





## Remote engine start

If the system is prepared for remote start, to execute it, press and hold  button for 3 seconds. Sound signal will confirm the command, LCD will show flashing engine operation icon  signifying preparation to the engine start. In a few seconds the engine will be started, the remote will play "ENGINE START" ringtone and show spinning engine operation icon .



Engine operation duration depends on system settings – either heating time or threshold temperature for engine stop.

To remotely stop the engine while it performs heating, press and hold  button for 2 or more seconds. The engine will be immediately stopped and it will be confirmed by the remote playing "ENGINE STOP" ringtone and engine operation icon  fading.



The remote will give notification 1 minute before designated engine stop:  icon will flash and "engine stop in 1 minute" ringtone will play every 10 seconds. Sending "Remote engine start" command will extend its operation period by 10 minutes. This procedure can be repeated multiple times.

## CODE IMMOBILIZER FUNCTION (PIN-TO-DRIVE)

Code immobilizer (pin-to-drive) is a function that allows disarming, disabling blocking and controlling timer channels using original vehicle controls (button, lever or pedal).

To enter the immobilizer code, switch on the ignition and press a programmed button a number of times equals to the first digit. Pauses between presses should not exceed 1 second. More than 1 second pause will be interpreted as the start of the next digit input. The immobilizer code can consist max of 4 digits from 1 to 9.

After entering a correct immobilizer code, depending on the settings, either the engine blocking will be disabled or a programmed time channel will be activated or the system will be disarmed. It is required to make additional connections and settings to use this function

**Additional settings or additional connections are required for the code immobilizer function.**

## SYSTEM SETTINGS MENU

Enter the main menu with **F** button short press. To switch between menu sections shortly press button **F**.

### **F** entering settings menu



- Control over engine preheater



- Control over car status, view event history



- Control over timer channels



- Remote and automatic engine start adjusting







sensors  
adjusting

F



- Sensors adjusting



Valet mode

F



- Maintenance mode of the car



siren  
sounds

F



- siren signals adjusting



14:45

F



- Time setting



sounds

F



- Sound notifications of the remote control



alarm clock

F



- Alarm clock setting



connect. lost:  
ringtone

F



- Notifications on loss of radio signal



06:30

F



- Alarm clock time adjusting

**F Exit settings menu**



anti-hi-jack

F





- Anti-hi-jack mode\*

To exit menu, press and hold **F** button for 1 second.

\* The function is not available in this model

## Engine heater

To switch on engine preheater, select “ENGINE HEATER MENU” and shortly press  button. To switch off preheater, shortly press  button. If preheater monitoring is enabled, LCD will display  con during engine preheater operation.

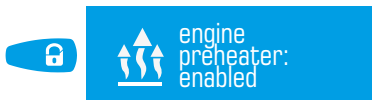



**Preheater operation is enabled**





**Preheater operation is disabled**

## Timer channels

Time channels can be used to implement additional functions and to control external devices. Timer channels can be adjusted via the Pandora Alarm Studio.

To enter “TIME CHANNELS MENU”, shortly press  button. The following presses of  button will cause switching between channels.

To activate/deactivate the channel, shortly press .

To exit menu, press and hold  button for 1 second.

1	2	3
4	5	6
7	8	9

channel  
controls



1

channel 1  
disabled



1

channel 1  
enabled



2

channel 2  
disabled



2

channel 2  
enabled



3

channel 3  
disabled



3

channel 3  
enabled



4

channel 4  
disabled



4

channel 4  
enabled



## Check car status

To receive information about engine, interior temperature, battery voltage and fuel level, select «SYSTEM CONTROLS» menu and shortly press  button.





To exit menu, press and hold  button for 1 second.

**NOTE: Engine start via temperature is available only if temperature sensor is connected. The sensor availability depends on the system set. Fuel level will only be shown if it can be read from CAN-bus or if there is additional connection.**

## Event history



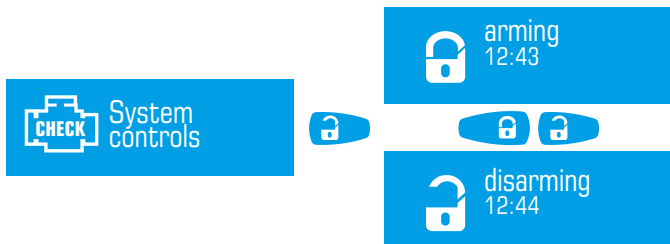

To view event history in the system's memory, select «SYSTEM CONTROLS» menu, then shortly press .



Navigate several last events using  (forward) and  (back) buttons. Events are displayed by showing time of the event and flashing corresponding trigger zone indicators.



## Automatic engine start

The system allows setting up modes of automatic engine start and stop. Synchronized real-time clock on the remote and base unit and other autonomous system settings allow many engine start options without needing to have the remote in command radio range.

Automatic start and engine work conditions programming is done using LCD remote. Shortly press  button to enter «REMOTE START SETTINGS» menu. Shortly press  button to switch between menu sublevels. Sub-level values are changed using  and  buttons.

When changing settings are done, the values should be saved. To do this, proceed to Send settings sublevel by pressing of  button and press  button to save new settings. Changes will be sent to the base unit, it will be confirmed with double sound signal of the remote.

To exit menu, press and hold  button for 1 second.

**NOTE: If you have not saved new settings, remote and automatic engine start settings will remain the same as before.**

**NOTE: Engine start via temperature is available only if temperature sensor is connected. The sensor availability depends on the system set.**



**WARNING!** Enable remote start if your local legislations allows driverless cars to have working engine.

 remote start  
settings 

F

 start  
by time  
enabled  

 start  
by time  
disabled

 start time  
07:30 **hours**   **minutes**

F

 start  
by temp  
enabled  

 start  
by temp  
disabled

F

 start temp  
-20° **increase**   **decrease**

F



work  
duration  
20 min

increase.



decrease

F



daily start  
enabled



daily start  
disabled

F



stop by temp  
enabled



stop  
by temp  
disabled

F



stop temp  
80°

increase



decrease

F



send settings



set selected modes

F

return to the beginning of the settings

## WIRES DESCRIPTION

### X4 Socket (main socket)

- **Wire 1 (White) (Tachometer input)** — Analog input of the tachometer signal, it connects to the tachometer wire or to the signal wire of a nozzle, which provide stable pulses of any polarity corresponding to the RPM.
- **Wire 2 (Red-black) (CH5)** — Factory setting is 'Opening trunk'. A negative output of additional channel with maximum load capacity 200mA. This output is multipurpose, it can operate in accordance with selected logic.
- **Wire 3 (Orange-white) (CAN-High)** — Wire of digital bus CAN-High It connects to an appropriate CAN-High wire of a car.
- **Wire 4 (Yellow-white) (CAN2-H/CH4)** — Wire of digital bus CAN2-High. It connects to an appropriate CAN2-High wire of a car. This channel can be assigned as an output (CH4), it will not work as a digital bus in this case.
- **Wire 5 (Gray) (INP2)** — Factory setting is 'Door switches'. This wire connects to a wire that becomes grounded when the door opens. This input is multipurpose, it can operate in accordance with selected logic.
- **Wire 6 (Green) (CH3)** — Factory setting is 'Turn indicators'. This wire connects to the hazard flashers button. A negative output of additional channel with maximum load current 200mA. This output is multipurpose, it can operate in accordance with selected logic.
- **Wire 7 (White-blue) (INP5)** — Factory setting is "Brake pedal" This wire connects to the brake pedal button where 12V voltage appears when the pedal is pressed (stop lights wire). Brake pedal signal is one of the system's security zones. This input is multipurpose, it can operate in accordance with selected logic. This input can be used as "Fuel level" input, calibration of the fuel level is performed by the VALET button.
- **Wire 8 (Black) ("Ground")** — This wire must be connected to the "Ground". This wire must be connected first during installation.
- **Wire 9 (Blue) (INP4)** — Factory setting is 'Neutral/Handbrake'. This wire connects to an appropriate wire of a car. This input is multipurpose, it can operate in accordance with selected logic.
- **Wire 10 (Brown-white) (INP3)** — Factory setting "Front hood switch". This wire connects to an appropriate wire that becomes grounded when the front hood opens. This input is multipurpose, it can operate in accordance with selected logic.
- **Wire 11 (Orange-black) («CAN-Low»)** — Wire of digital bus CAN-Low. It connects to an appropriate CAN-Low wire of a car.
- **Wire 12 (Yellow-black) (CAN2-L/CH2)** — Wire of digital bus CAN2-Low. It connects to an appropriate CAN2-Low wire of a car. This channel can be assigned as an output (CH2), it will not work as a digital bus in this case.



- **Wire 13 (Blue-black) (CH1)** — Factory setting is 'Beeper'. A negative output of additional channel with maximum load current 200mA. This output is multipurpose, it can operate in accordance with selected logic.
- **Wire 14 (Yellow) (INP6)** — Factory setting is 'Ignition'. This wire connects to ignition switch or to an appropriate wire where 12V voltage appears when ignition is enabled and doesn't disappear until the moment ignition is disabled. This input is multipurpose, it can operate in accordance with selected logic.
- **Wire 15 (Purple) (CH11)** — Factory setting is "Siren". It connects to siren control wire (+) (maximum load current is 2A). This channel is multipurpose, it can operate as input or output in accordance with selected logic.
- **Wire 16 (Red) (Power supply +12V)** — This wire must be connected to a reliable conductor with constant voltage of 12V.

## X5 Socket (Relay module)

- **Wire 1 (Blue) (CH7)** — Factory setting is 'Blocking N.O.'. This output is used to control blocking relay with a normally open logic (it becomes grounded on switching on the ignition when the system is disarmed). An output of additional channel with maximum load current 200mA. This output is multipurpose, it can operate in accordance with selected logic.
- **Wire 2 (Orange) (CH6)** — Factory setting is 'ACC'. The channel is used to control accessories. If the 'Car with START/STOP button' setting is enabled, the channel will control brake pedal during remote or automatic engine start. An output of additional channel with maximum load current 200mA. This output is multipurpose, it can operate in accordance with selected logic.
- **Wire 3 (Brown) (CH9)** — Factory setting is 'Ignition'. This output is used to switch on the ignition. It allows implementing automatic engine start, turbo timer, ignition support and connecting to ignition in series (incut). If the 'Car with START/STOP button' setting is enabled, the channel will operate in impulse mode to control the button. A negative output of additional channel with maximum load current 200mA. This output is multipurpose, it can operate in accordance with selected logic.
- **Wire 4 (Green) (CH8)** — Factory setting is 'Bypass'. Output activates during remote or automatic engine start. A negative output of additional channel with maximum load current 200mA. This output is multipurpose, it can operate in accordance with selected logic.
- **Wire 5 (Yellow) (CH10)** — Factory setting is 'Starter'. This output is used to switch on the starter of a car. A negative output of additional channel with maximum load capacity 200mA. This output is multipurpose, it can operate in accordance with selected logic. **It is not recommended to use any other channel as the Starter output.**
- **Wire 6 (Red)** — +12V Power supply of the relay module.

For remote engine start

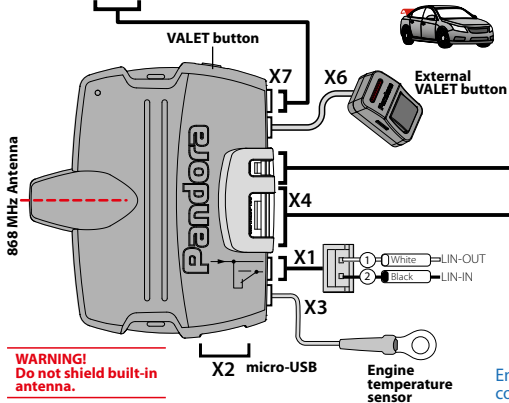
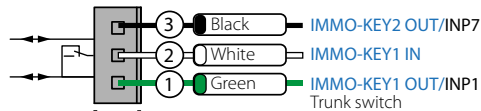

868 MHz Antenna

**WARNING!**  
 Do not shield built-in antenna.

Sockets

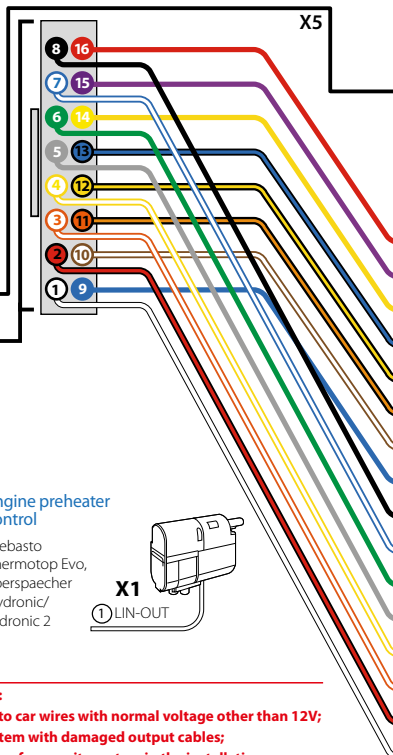
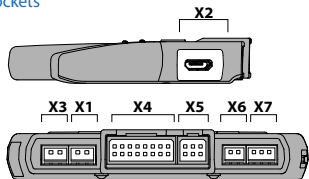

Engine preheater control

Webasto  
 Thertmotop Evo,  
 Eberspaecher  
 Hydronic/  
 Hidronic 2

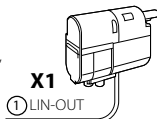

**IT IS FORBIDDEN TO:**

- connect the system to car wires with normal voltage other than 12V;
- install a security system with damaged output cables;
- bypass original fuses of a security system in the installation process.

**WARNING!** Before starting the installation of the system, select a car model in the Alarm Studio (CAN-bus protocol)

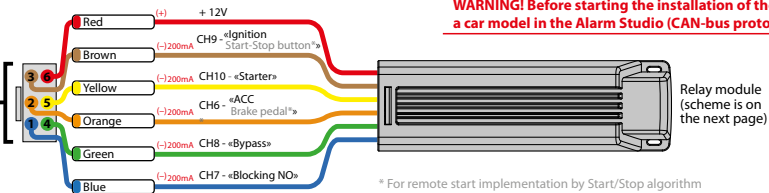

\* For remote start implementation by Start/Stop algorithm

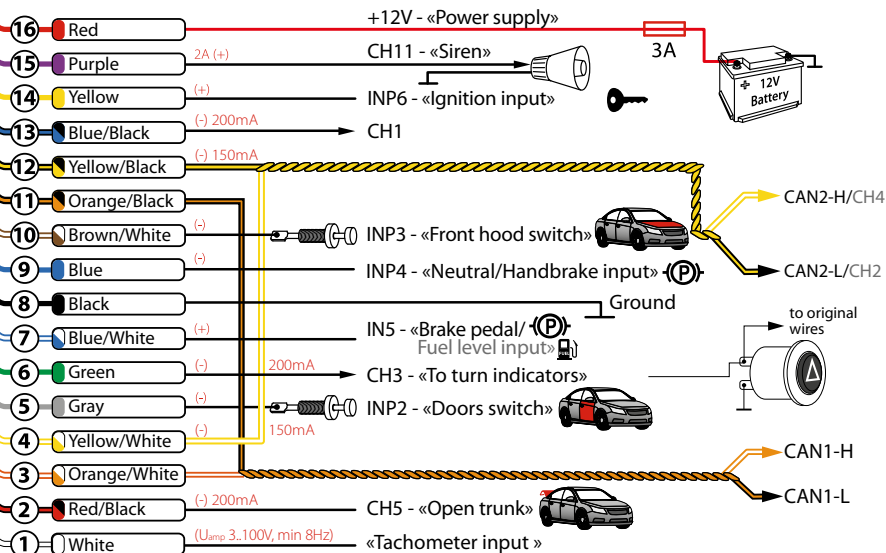

**Pandora** Light

# Pandora

## Relay module RMD-5M

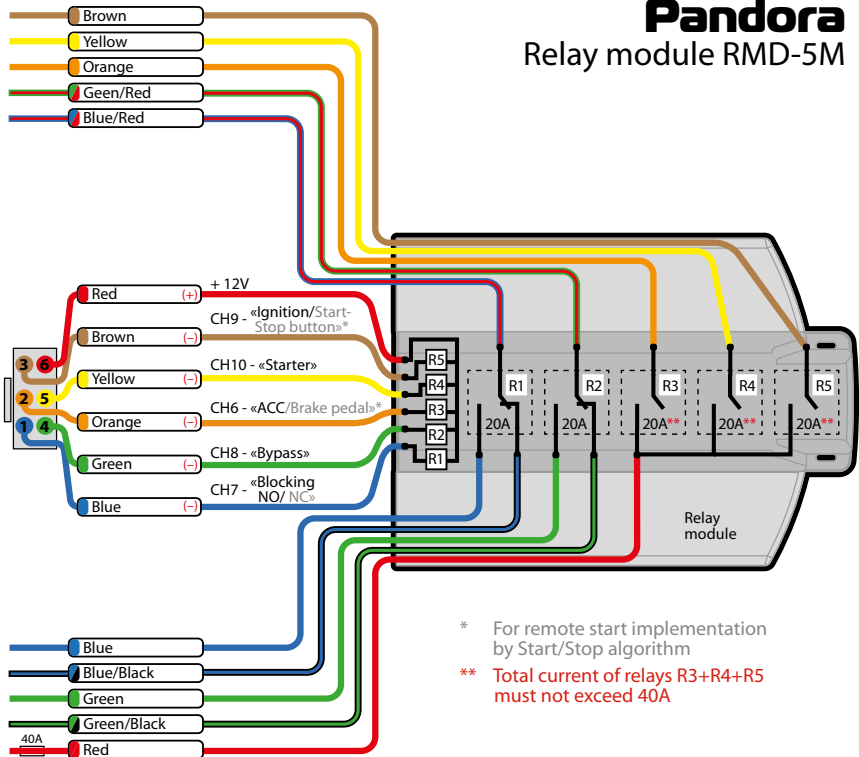





## X7 Socket (Multifunctional channels)

Use this socket when implementing bypass of original immobilizer using IMMO-KEY1 and IMMO-KEY2 multifunctional channels. Deselect any logic of INP1 and INP7 inputs in settings. Make connections in accordance with installation scheme. The settings of the socket are available in Alarm Studio. Disconnect the system from power supply after changing the settings.

- **Wire 1 (Green) (IMMO-KEY1 OUT/INP1)** — Factory setting is 'Trunk input'. This wire connects to an appropriate wire that becomes grounded when the trunk opens. This input is multipurpose, it can operate in accordance with selected logic.
- **Wire 2 (White)** — This channel is used to brake the circuit of original immobilizer (it connects in accordance with an installation scheme).
- **Wire 3 (Black) (IMMO-KEY2 OUT/INP7)** — Factory setting is «Free input». This input is multipurpose, it can operate in accordance with selected logic.

## SENSOR SETTINGS

The system allows to adjust shock/motion/tilt sensors using the remote control.

Shortly press  button to enter «SENSOR SETTINGS» menu. Shortly press  button to switch between menu sublevels of the shock/motion/tilt sensors. The sensitivity of a sensor are increased using  button and decreased using  button. Maximum sensitivity value is 50 and minimum is 0

Press and hold  button for 1 second to save new sensitivity level.





Enter the menu









press to enter the sublevels

### Shock sensor settings

For prompt remote adjusting of shock sensor sensitivity, select «SHOCK SENSOR» submenu by short presses of  button. Short presses of  button will cause switching between functions. To save new settings of shock sensitivity control, shortly press  button.

To enter «Shock sensor warning/alarm level» submenu, shortly press  button. Sensor sensitivity can be set with short presses of  and  buttons.

To save new settings of the sensor, press and hold  button for 1 second.

To exit menu, press and hold  button for 1 second.

 shock sensor  
enabled



shortly press to save



 shock sensor  
warn level  
disabled



shortly press to save



 shock sensor  
alarm level  
disabled



shortly press to save

increase   decrease

 adjusting  
shock sensor  
-  + warn. lvl. = 35

F



 adjusting  
shock sensor  
-  + warn. lvl. = 30

increase   decrease



press and hold for  
1 sec. to save

## Motion sensor settings

For prompt remote adjusting of motion sensor, select «MOTION SENSOR ADJUSTMENT» submenu by short presses of **F** button. The sensor sensitivity can be set with short presses of  and  buttons. To save new settings of the sensor, press and hold  for 1 second.

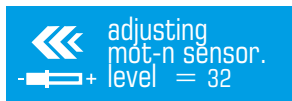



increase   decrease

 **press and hold for 1 sec. to save**

To exit menu, press and hold **F** button for 1 second.

## Tilt sensor settings

For prompt remote adjusting of motion sensor, select «TILT SENSOR ADJUSTMENT» submenu by short presses of **F** button. The sensor sensitivity can be set with short presses of  and  buttons. To save new settings of the sensor, press and hold  for 1 second.



increase   decrease

 **press and hold for 1 sec. to save**

To exit menu, press and hold **F** button for 1 second.



## Siren signal settings

To configure siren sounds, select «SIREN SETTINGS» menu. Select one of the siren sound options using  button. To save new settings, shortly press  button.



**all sound signals are enabled**



**warning signals are disabled**



**warning and alarm signals are disabled**



**shortly press to save**

To exit menu, press and hold  button for 1 second.

## Sound notification settings

This function disables all sound signals of the remote control, this mode does not apply to alarm clock and main zones triggering. LED indication and vibration remain enabled.

To set one of two notification options, select «SOUNDS» menu. Short presses of  will cause switching between menu settings. This mode doesn't require to save.



**sound signals are enabled**



**sound signals are disabled**

To exit menu, press and hold **F** button for 1 second.

### Radio channel control settings

There are 3 options to notify when the owner is not in radio coverage zone. Select «CONNECTION LOST» menu, short presses of  button will cause switching between menu settings. This mode does not require to save.



**«Connection lost» ringtone notification**



**alarm signal**





**all notification are disabled**

To exit menu, press and hold **F** button for 1 second.

## Service/Valet mode

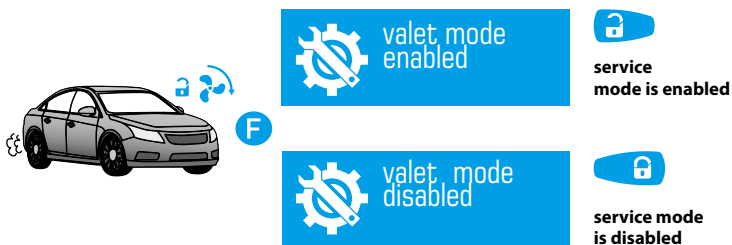

It is recommended to put system into service mode before handing it to the car service or valet parking. When this mode is switched on, security system stops interfering with built-in electronics and disables all functions to ease maintenance or parking. Moreover, you will not have to leave the remote control or radio tag to the valet or the mechanic. Disabling valet mode is not possible without using the main remote. This feature is implemented to prevent recording additional remotes during maintenance without the owner knowing.

To activate service mode when ignition is switched on and a radio tag is in the coverage zone (if Immobilizer or Anti-hijack mode is activated), select «VALET MODE» and shortly press  button. The system will confirm enabled maintenance mode with green flash of LED indicator of the VALET button when ignition is switched on. To exit this mode, select Valet mode and shortly press  button.



To exit menu, press and hold  button for 1 second.



## Time settings

To set up time, select «TIME» menu. With short presses of  button set hours, with short presses of  set minutes. This mode does not require to save.



To exit menu, press and hold  button for 1 second.

## Alarm clock settings

To set up the alarm clock, select «ALARM CLOCK» menu. Enable alarm with short press of  button or disable it with short press of  button.



Setting of alarm clock is similar to clock setting.



## Replacing a battery in the remote control

If high quality batteries are used, service-security system remote can function up to 4 months without needing a replacement. Battery needs to be replaced if the remote control is not turning on or the icon  has only one bar left and starts flashing.

To replace the battery:

- move battery cover lock in the direction shown with arrow;
- take the battery out and place a new one on its place;
- the remote is ready for use (switch it on by pressing and holding  button for 3 seconds)

**It is recommended to keep an extra AAA battery.**



## CONTROL OVER THE SYSTEM IN CASE OF EMERGENCY

In case you cannot disarm the system using a phone or immobilizer tag, the 'Secret PIN-code' can be used. The 'Secret PIN-code' is written on the owner's plastic card under protective layer. Erase the protective layer and use the VALET button to input the PIN-code.

The code must be entered only when the base unit is powered and the ignition is switched off. The PIN-code can be entered using the external or located on the base unit VALET button. The digits input and correct input is indicated by the external or located on the base unit LED indicator.



**ATTENTION!** Make sure that the protective layer on the owner's plastic card is intact after the installation of the system. The plastic card hold the 'Secret PIN-code'.



**ATTENTION!** Remove the protective layer carefully. Do not use any sharp objects to avoid damaging of hidden information under the protective layer.



**ATTENTION!** It is highly recommended to change factory preset of the 'Service PIN-code' for improving security of the system.

### ENTERING THE PIN-CODE:

- Enter the first digit of the code using the VALET button. Press the button a number of times, equals to the first digit. Pauses between presses should not exceed 1 second. Each pressing will be confirmed with an orange LED indicator flash. Pause for more than 1 second and a red LED indicator flash confirm the input of the first digit. Then you can enter the next digit

- Enter the second digit of the code using the VALET button. Press the button a number of times, equals to the second digit. Pauses between presses should not exceed 1 second. Each pressing will be

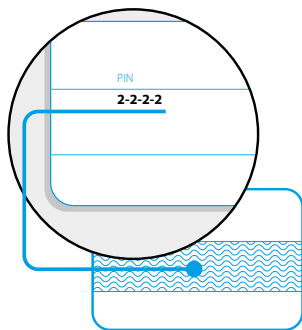

### VALET BUTTON

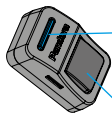

Three-color status LED indicator (green, red, orange)

VALET button

confirmed with an orange LED indicator flash. Pause for more than 1 second and a red LED indicator flash confirm the input of the second digit. Then you can enter the next digit.

- Enter the third digit of the code using the VALET button. Press the button a number of times, equals to the third digit. Pauses between presses should not exceed 1 second. Each pressing will be confirmed with an orange LED indicator flash. Pause for more than 1 second and a red LED indicator flash confirm the input of the third digit. Then you can enter the next digit.

- Enter the fourth digit of the code using the VALET button. Press the button a number of times, equals to the fourth digit. Pauses between presses should not exceed 1 second. Each pressing will be confirmed with an orange LED indicator flash. The correct input will be confirmed with the series of green and red flashes of the LED indicator.

If the input was incorrect, it will be indicated with a long red flash of the LED indicator and the system will stay in previous state. New input can be attempted after 5 seconds.

- If the input was correct, the system will be disarmed.
- If the input was incorrect, it will be indicated with a long red flash of the LED indicator and the system will stay in previous state. New input can be attempted after 5 seconds.
- If the system was disarmed and the ignition was off, it will enter the programming mode after entering the correct input.
- For emergency arming when the engine is stopped, press and hold VALET button for 3 seconds. The system will be armed in 30 seconds. The LED indicator is lighting red during the countdown

## PROGRAMMING THE SYSTEM

### Entering the programming mode

To change the system settings or program the system using a computer or VALET button, the system must be in the programming mode. Enter the programming mode by entering the 'Service PIN-code' (factory preset is 1-1-1-1). The PIN-code should be entered using the external or located on the base unit VALET button. The input is indicated by flashes of the external or located on the base unit LED indicator. You can enter the code only if the base unit is powered from the USB socket or from an external power supply, the ignition is off, the system is disarmed and service mode is switched off.

If there is no 'Service PIN-code', you can enter the programming mode using the 'Secret PIN-code' written on the owner's card.



**ATTENTION!** You can find the detailed instructions for entering the PIN code in the 'Control over the system in case of emergency' section.

Status indicators lights during PIN-code entering	
LED state	Description
Short orange flash	Confirmation of pressing the VALET button
Short red flash	Confirmation of entering a digit
Red and green flashes	PIN-code is correct
Long red flash	PIN-code is incorrect

### Exiting the programming mode

To exit the programming mode, turn on the ignition or turn off power of the base unit. The system will reboot programmatically (all changes will be saved) after exiting programming mode using the ignition. All ways to exit the programming menu are accompanied by sound signals of the siren/beeper and light signals of the LED indicator. Light signals indicate the number of recorded remote controls.

## Preparing to program the system using a computer

The system allows programming all settings and updating software of the base unit via a micro-USB cable. If the base unit has not been installed in the vehicle yet, it will be powered via a micro-USB cable while programming. To program using a computer, you need a standard USB cable, a computer with the Windows XP/Vista/7/8/10 and the Pandora Alarm Studio application (you can download it from [pandorainfo.com](http://pandorainfo.com)).

It is required to create an account in the Alarm Studio to use the Pandora CLONE for the remote engine start (you can register without a connection to a system). The Pandora CLONE procedure requires an Internet connection.

In preparation to programming, the following steps should be followed:

- Connect the system with a PC using a USB cable;
- Run the Pandora Alarm Studio
- Enter the programming menu by entering the service PIN-code.
- The application will automatically find the system.

## Updating firmware

It is recommended to update firmware of the base unit before installing and programming the system. You can update firmware using the Alarm Studio application after entering programming mode or using quick boot algorithm (the PIN-code is not required).

Quick boot mode: open the Alarm Studio; de-energize and disconnect the system; press and hold the VALET button located on the base unit; release the button immediately after connecting the system and a computer via USB cable; the system will enter boot mode.



**ATTENTION!** If the boot mode has been interrupted for some reason and the status indicator lights red, you need to load firmware using quick boot mode (without entering the PIN-code).

## Programming using the VALET button

The system allows programming some settings using the VALET button. To configure all settings use a computer to program the system.

Enter the programming mode by entering the “Service PIN-code”, Use the VALET button to enter the desired level number (press the button a number of times, equals to the level number; pauses between presses should not exceed 1 second). The system will confirm correct input with red LED flashes and short sound signals of a siren and proceed to the desired level. If the input was incorrect, the system will not confirm input and will await a new level input after a series of green and red flashes.





Level 1	Recording remote controls (D-011)
Level 2	Changing the factory preset of the “Service PIN-code”
Level 3	Recording the idle speed to the system memory
Level 4	Resetting to factory settings
Level 11	Programming and configuring the “Immobilizer code”
Level 12	Fuel level calibration
Level 17	Programming bypass of original immobilizer

## Level 1 – Recording remote controls

Prepare to record all remote controls (you can record up to 4 remote controls), install batteries in the remote controls. If the main LCD remote control is off, switch it on in accordance with its manual.

Enter programming menu and then press the VALET button once. The LED indicator will light green and the system will enter the remote controls recording mode. Remote controls are recorded (paired) one by one, in any order and without time limit. All previously recorded remote controls will be removed when you overwrite new remote controls or record old remote controls again.

### Recording remote controls:

Press three buttons    simultaneously and hold them for 1 second (until a short beep from the main remote control or until LED fading of an additional remote), then release the buttons. If recording was successful, the LCD remote will emit 2 short beeps and the base unit will emit 1 beep, after that you can move to recording the next remote control.

### Saving changes:

To finish recording, press the VALET button once. The series of red and green flashes of the status LED indicator will confirm saving.

## Level 2 – Changing the factory preset of the “Service PIN-code”

Prepare a new value of the “Service PIN-code”, it should consist of 4 digits (from 1 to 9). Write down or remember the new PIN-code. Enter programming menu and then press VALET button twice. The system will enter «Changing Service PIN-code» mode and the status LED indicator will turn off.

### Changing the “Service PIN-code”:

- Enter the first digit of the code using the VALET button. Press the button a number of times, equals to the first digit. Pauses between presses should not exceed 1 second, every pressing will confirm with an orange LED indicator flash. Pause for more than 1 second and a red LED indicator flash confirms the input of the first digit. Then you can enter the next digit;

- Enter the other numbers in the same manner. The input of the fourth number will be confirmed by the series of red and green LED indicator flashes. The system will wait for PIN-code re-entering;
- Enter all four digits again.

If you were able to correctly enter the “Service PIN-code” twice, the indicator will produce the series of red and green flashes, new PIN-code will be recorded, the system will return to programming mode. In case of the incorrect code input the indicator will be lit red, the system will return to programming mode.

### Level 3 – Recording the idle speed to the system memory

To timely turn off the starter during automatic or remote engine start via digital or analog tachometer input and the correct operation of the «Smart Turbo Timer», it is necessary to record the engine idle speed.

To record the idle speed to the non-volatile system memory, enter the programming menu. Press the VALET button three times. Switch on the ignition and start the engine after entering this level of programming (the engine should be warmed-up, idle speed should match the stable idle speed of the warmed-up engine). The system will confirm the presence of the idle speed status with green flashes of the LED indicator. Wait until the stable idle speed will be reached and save the changes.

#### **Saving changes:**

Press the VALET button once to save idle speed. Successful recording of the idle speed will be confirmed with the series of red and green flashes of the LED indicator. The system will exit programming menu and reboot after saving the idle speed.

### Level 4 – Resetting to factory settings

The procedure recovers the factory settings of the system without deleting previously registered devices (tags, mobile device, relays, etc.) that is stored in the non-volatile memory.

To reset the settings enter the programming mode and press the VALET button four times. Press and hold the VALET button for more than 4 seconds until a siren sound, then release the button. The system will confirm the resetting to the factory settings with a long red flash of the LED indicator. After that the system will return to a programming mode.

### Level 11 – Programming and configuring the “Immobilizer code”

To program the «Immobilizer code», enter the programming mode and press the VALET button 11 times. The level is divided into 3 sublevels (Sublevel 11.1 – Selecting buttons; sublevel 11.2 entering the PIN-code; sublevel 11.3 – confirmation of the PIN-code input).

The system will automatically enter the sublevel 11.1 (Selecting buttons) after entering the level 11. The system can determine buttons via analog “Code immobilizer” input or via digital protocol of a

car. It is necessary to configure an analog input (INP) as “Code immobilizer” in the settings of the base unit inputs when implementing the “Code immobilizer” via an analog input. It may be necessary to switch on the ignition after entering the level 11 of programming (if the car bus is active only when the ignition is switched on) when implementing the “Code immobilizer” via digital car bus protocol.

After selecting active buttons enter the sublevel 11.2 (Entering the PIN-code) by one pressing of the VALET button. Program PIN-code using selected buttons at this sublevel; press the VALET button once and enter PIN-code again. To confirm PIN-code re-entering and save all the settings, press the VALET button once again.

#### **Sublevel 11.1 – Selecting buttons:**

This sublevel is used to select active buttons via digital protocol of a car or via the “Code Immobilizer” analog input. To determine the activity of the analog “Code Immobilizer” input, apply potential to the corresponding input (INP) of the base unit, LED indicator will be flashing orange. If you determine buttons via digital protocol, select one or more buttons (up to four) for entering the secret code of the immobilizer. To do this press the selected button, LED indicator will confirm input with orange flashes. If there are no orange flashes when any button is pressed, then this button is not recognized by the system, select a different button. Repeat the procedure to select the second, third, fourth button and enter the next sublevel. To enter the next sublevel press the VALET button once.

#### **Sublevel 11.2 – Entering the PIN-code:**

Program the immobilizer deactivation PIN-code using the selected button or buttons. Enter the first digit by pressing the previously selected button (pauses between presses should not exceed 1 second). The base unit will confirm entering with a red flash of the LED indicator. Enter the second (third, fourth) digit by pressing the previously selected button. The base unit will confirm entering of each digit with red flash of the LED indicator.

Input the required number of digits (up to 4) and then press VALET button. The system will confirm receiving of the secret validator code with long red flash of LED indicator and will wait for confirmation of PIN-code.

#### **Sublevel 11.3 - Confirmation of the PIN-code input:**

Enter the PIN-code again similarly to the procedure (level 11.2 – Entering the PIN-code) and press the VALET button. The system will confirm correct PIN-code with red and green flashes of the LED indicator and will memorize the PIN-code, and then the system will proceed to the programming mode awaiting level input. Incorrect confirmation is indicated with a long red flash of LED indicator, after that the system will return to the programming mode.



## **Level 12 – Fuel level calibration**

### **To control fuel level, make connection and configure the settings:**

- Setting is performed via the Pandora Alarm Studio. The “Use INP to control fuel level” item should be enabled in the settings, the factory setting of this input (input settings) must be unselected.

- Make a connection in accordance with the “Fuel control input” scheme. To define the current fuel level, calibration should be performed at least by two points. In some cases fuel level calibration should be performed by all specified points (for more exact definition).

**Fuel level calibration:**

- Select the desired sub-level corresponding to the current fuel level. The total number of sublevels are 12 (listed in the table).
- Enter the programming level 12. The LED indicator will be red and the system will enter to the sublevel 12-0 (0%). Enter the number of the desired sublevel (10-100%) by pressing the VALET button (press the button a number of times equals to a digit; pauses between presses should not exceed 1 second).
- Run the engine no less than in 1 minute, then press VALET button – the data will be sent to the base unit.
- Press the lock button  to save the setting.
- If you want to cancel the current setting, press the unlock button .
- Repeat the procedure for the second and next calibration points.
- To exit the programming mode, enter sublevel 12 or press VALET button more than 12 times.

To reset all calibration values, proceed to the sublevel 11 (do not switch on the ignition). Reset confirmation is performed by pressing the lock button , exit without confirmation and exit the menu are performed by pressing the VALET button.

Sublevel	Fuel level
12-0	0%
12-1	10%
12-2	20%
12-3	30%
12-4	40%
12-5	50%
12-6	60%
12-7	70%
12-8	80%

12-9	90%
12-10	100%
12-11	Reset all calibration values
12-12	Exit the programming mode

### **Level 17 – Programming bypass original immobilizer**

Bypass learning procedure is performed on this level. A detailed manual can be found in installation scheme for a car in the Alarm Studio.

## ADDITIONAL INFORMATION

### Siren sound and turn light signals

Signal name	Signal Description
Alarm, PANIC mode	Incessant sound and light signals for 30 sec.
Arming	1 sound signal / 1 light signal
Disarming	2 sound signal / 2 light signals
“Sensors were triggered” signal when disarming	4 sound signal / 4 light signals
“Sensor malfunction” signal when arming	4 sound signal / 4 light signals
Warning level of sensors is triggered	3 sound signal
Car search	5 sound signal / 5 light signals

### Meaning of the LED indicator colors

Indicator status	Meaning
Short red flashes	The system is armed
Lit red	The system is preparing for automatic arming
Orange flash	Confirms VALET button press
Orange flashes (when switching on the ignition)	Confirms a number of recorded remote controls
Red and green flashes	PIN-code input confirmation
Faded	The system is disarmed

## Checking the number of recorded remote controls

The number of recorded remote controls can be checked by the number of orange flashes of the LED indicator. Number of registered remote controls device can be checked every time the ignition is switched on when the system is disarmed. The number of orange LED flashes will indicate the number of recorded remote controls.

You can also check the number of recorded remote controls by taking off and putting back on battery terminal. The system will emit short sound signals from a siren with less than 1 sec. interval. The number of the signals equals to the number of recorded remote controls.

## System modules layout

Ask the installer to mark system's modules on the picture provided. This information can be important for diagnostics in case system malfunctions.

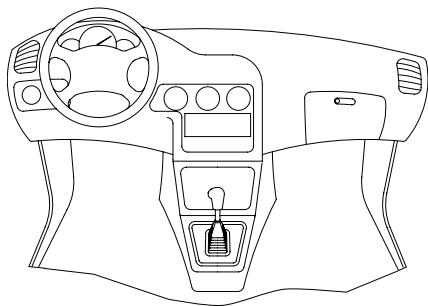

- ① Base unit
- ② Valet button
- ③ Blocking relay
- ④ Relay module

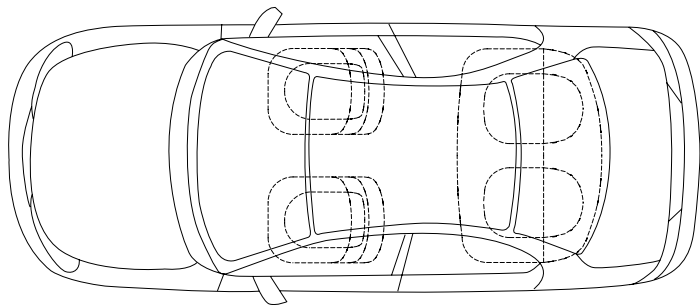



## WARRANTY OBLIGATIONS

Manufacturer guarantees correct operation of the service-security system if exploitation, installation, storage and transportation conditions described in this manual were met.

The system should only be used according to installation scheme and user manuals. The system is meant to be installed by the professional car electronics installers. We recognize that outside Russia the system can be installed by amateurs – those installations are still a subject of limited warranty. The installer should fill in installation certificate that is included in this manual.

Parts malfunctioning during warranty period on the fault of the manufacturer should be repaired or replaced by the installation center of the manufacturer or by certified service center. List of certified service centers outside Russia can be found on [pandorainfo.com](http://pandorainfo.com)

The user loses the right for warranty services in the following cases:

- when warranty period expires;
- if exploitation, installation, storage or transportation conditions were not met;
- if there is mechanical damage of the external parts of the system after it is sold. This includes: fire damage, consequential damage in case of car accident, aggressive liquids and water seeping damage, damage caused by improper use;
- if the damage was caused with incorrect settings and parameter adjustment;
- if system devices are replaced with any devices that are not recommended by the manufacturer;
- if manufacturer sealing is broken;
- if there is no properly filled warranty card and installation certificate.

Warranty period is 3 years since the moment of purchase, but no more than 3,5 (three and a half) years since the moment of production. This warranty does not include batteries of the remotes, as they have their own service life time. Maintenances and repairs of the system with expired warranty period are carried out at the expense of the user on separate contracts between the user and the installer/service center.

### Transportation rules

Products should be transported in the original packaging by any means of transport as long as they are protected from mechanical damage and precipitation. Packaged products should be stored on racks in piles of 6 or less boxes, in enclosed, dry, heated rooms (no less than 1 m from heating) which exclude possible interaction with moisture, oil products and damaging environmental factors.



**ATTENTION!** We recommend you to ask an installer to fill out the installation certificate and warranty card. These documents may be required for contacting the customer support.

## Installation certificate

I, the undersigned \_\_\_\_\_

Position, name

professional installer, certify that installation of the service-security system, specified below, was carried out by me in accordance with manuals and schemes provided by the manufacturer.

### Car specifications:

Car model \_\_\_\_\_

Type \_\_\_\_\_

ID number (VIN) \_\_\_\_\_

Registration number \_\_\_\_\_

### Security system specifications:

Model **Pandora Light**

Serial number \_\_\_\_\_

Service center name, full address and installer's stamp \_\_\_\_\_

\_\_\_\_\_

\_\_\_\_\_

Signature \_\_\_\_\_ / \_\_\_\_\_ /

Signator

Work accepted \_\_\_\_\_ / \_\_\_\_\_ /

Signator

Date « \_\_\_\_ » \_\_\_\_\_ 20\_\_ y.

## Acceptance certificate

Model **Pandora Light** is in conformity with Electromagnetic Compatibility Directive EMC 2004/108/EC and R&TTE Directive 1999/5/EC

Serial number \_\_\_\_\_

Date of production \_\_\_\_\_

Responsible person's signature

(stamp)

Packager \_\_\_\_\_

Signature (personal stamp)

-----

## Warranty card

Model **Pandora Light**

Serial number \_\_\_\_\_

Date of purchase « \_\_\_\_ » \_\_\_\_\_ 20\_\_ y

\_\_\_\_\_  
Seller's (installer's) stamp

Seller's signature \_\_\_\_\_

